



## Operation Manual

Lancer Corporation  
6655 Lancer Blvd.  
San Antonio, Texas 78219  
800-729-1500



Technical Support/Warranty  
800-729-1550  
custserv@lancercorp.com  
lancercorp.com  
PN: 28-0883/05

# TABLE OF CONTENTS

## ABOUT THIS MANUAL

This booklet is an integral and essential part of the product and should be handed over to the operator after the installation and preserved for any further consultation that may be necessary. Please read carefully the guidelines and warnings contained herein as they are intended to provide the user with essential information for the continued safe use and maintenance of the product. In addition, it provides **GUIDANCE ONLY** to the user on the correct services and site location of the unit.

***The installation and relocation, if necessary, of this product must be carried out by qualified personnel with up-to-date safety and hygiene knowledge and practical experience, in accordance with current regulations.***

<b>IMPORTANT SAFETY INSTRUCTIONS.....</b>	<b>3</b>
Intended Use.....	3
Power Warning.....	3
CO <sub>2</sub> Warning.....	3
Water Notice.....	3
<b>SPECIFICATIONS AND FEATURES.....</b>	<b>4-6</b>
Multi-brand Tower Specifications.....	4
Single Brand Tower Specifications.....	5
General System Overview - Multibrand Tower.....	6
General System Overview - Single Brand Tower.....	6
<b>PRE-INSTALLATION CHECKLIST.....</b>	<b>7</b>
<b>INSTALLATION.....</b>	<b>8-11</b>
Unpacking the Dispenser.....	8
Selecting/Preparing a Counter Location.....	8
Tower Installation.....	9
Junction Box Installation.....	9-10
Adjust Water Flow Rate & Syrup/Water Ratio.....	11
Volumetric Valve Adjustment.....	11
<b>PROGRAMMING AND CONFIGURATION.....</b>	<b>12-13</b>
Programming Overview.....	12

## BEFORE GETTING STARTED

Each unit is tested under operating conditions and is thoroughly inspected before shipment. At the time of shipment, the carrier accepts responsibility for the unit. Upon receiving the unit, carefully inspect the carton for visible damage. If damage exists, have the carrier note the damage on the freight bill and file a claim with carrier. Responsibility for damage to the dispenser lies with the carrier.

Valve Configuration.....	12
Purge Mode.....	13
Timed Pour Mode.....	13
Portion Control Programming.....	13
<b>CLEANING AND SANITIZING.....</b>	<b>14-15</b>
General Information.....	14
Cleaning and Sanitizing Solutions.....	14
Daily Cleaning.....	14
Weekly Cleaning and Sanitizing.....	15
Cleaning and Sanitizing Syrup Lines - BIB.....	15
<b>TROUBLESHOOTING.....</b>	<b>16-18</b>
<b>ILLUSTRATIONS AND PART LISTINGS.....</b>	<b>20-29</b>
Electronics Board - LFCV.....	20
Electronics Board - VV.....	21
Nozzle Assembly - LFCV.....	22
Nozzle Assembly - VV.....	23
LFCV Spare Parts.....	24
Water, Volumetric Valve Spare Parts.....	25
Misc. Spare Parts.....	26
Wiring Diagram - LFCV.....	27
Wiring Diagram - VV.....	28
Counter Cutout.....	29

# SAFETY NOTICES

## READ ALL SAFETY INSTRUCTIONS BEFORE USING THIS UNIT.

This manual contains important safety information and all applicable safety precautions must be observed. To reduce the risk of fire, electric shock, damage to the equipment or personal injury when using this unit all instructions/warnings on the product being used must be followed:

### **⚠ WARNING**

Text following the Warning signal indicates a hazardous situation, which if not avoided, will result in death or serious injury. Be sure to read all Warning statements before proceeding with the installation.

### **⚠ CAUTION**

Text following the Caution signal indicates a hazardous situation, which if not avoided, could result in death or serious injury. Be sure to read the Caution statements before proceeding with the installation.

### **⚠ ATTENTION**

Text following the Attention signal addresses a situation that if not followed could potentially damage the equipment. Be sure to read the Attention statements before proceeding.

### **NOTE**

Text following the Note signal provides you with information that may help you more effectively perform the installation procedures within this manual. Disregarding information will not cause damage or injury, however it may limit the performance of the dispenser.

# IMPORTANT SAFETY INSTRUCTIONS

## Intended Use

- The dispenser is for indoor use only
- This appliance is intended to be used in commercial applications such as restaurants or similar.
- This appliance should not be used by children or infirm persons without supervision.
- This appliance is not intended for use by persons (including children) with reduced physical, sensory or mental capabilities, or lack of experience and knowledge, unless they have been given supervision or instruction concerning use of the appliance by a person responsible for their safety.
- This appliance can be used by children aged from 8 years and above and persons with reduced physical, sensory or mental capabilities or lack of experience and knowledge if they have been given supervision or instruction concerning use of the appliance in a safe way and understand the hazards involved.
- Cleaning and user maintenance shall not be performed by children without supervision.
- This unit is not a toy and children should be advised not to play with the appliance.
- The min/max ambient operating temperature for the dispenser is 40°F to 105°F (4°C to 31°C).
- Do not operate unit below minimum ambient operation conditions.
- Should freezing occur, cease operation of the unit and contact authorized service technician.
- The maximum tilt for safe operation is 5°.
- This appliance must be installed and serviced by a professional.

## Carbon Dioxide (CO<sub>2</sub>)

- **WARNING:** Carbon Dioxide (CO<sub>2</sub>) is a colorless, noncombustible gas with a light pungent odor. High percentages of CO<sub>2</sub> may displace oxygen in the blood.
- **WARNING:** Prolonged exposure to CO<sub>2</sub> can be harmful. Personnel exposed to high concentrations of CO<sub>2</sub> gas will experience tremors which are followed by a loss of consciousness and suffocation.
- **WARNING:** If a CO<sub>2</sub> gas leak is suspected, immediately ventilate the contaminated area before attempting to repair the leak.
- **WARNING:** Strict attention must be observed in the prevention of CO<sub>2</sub> gas leaks in the entire CO<sub>2</sub> and soft drink system.

## Power

- Follow all local electrical codes when making connections.
- Check the dispenser name plate label, located in junction box for the correct electrical requirements of unit. **DO NOT** plug into a wall electrical outlet unless the current shown on the serial number plate agrees with local current available.
- Each dispenser must have a dedicated electrical circuit.
- **DO NOT** use extension cords with this unit.
- **DO NOT** 'gang' together with other electrical devices on the same outlet.
- **WARNING:** Always disconnect electrical power to the unit to prevent personal injury before attempting any internal maintenance.
- The resettable breaker switch should not be used as a substitute for unplugging the dispenser from the power source to service the unit.
- Only qualified personnel should service internal components of electrical control housing.
- **WARNING:** Make sure that all water lines are tight and units are dry before making any electrical connections
- If this dispenser is installed in an area that is susceptible to more than 10% variation of the nominal line voltage, consider installing a surge protector or similar protection device.

## Water Notice

- Provide an adequate, potable water supply. Water pipe connections and fixtures directly connected to a potable water supply must be sized, installed, and maintained according to federal, state, and local codes.
- The water supply line must be at least a 3/8 inches (9.525 mm) pipe with a minimum of 20 PSI (0.137 MPA) line pressure, but not exceeding a maximum of 50 PSI (0.345 MPA). Water pressure below 20 PSI (0.137 MPA) will require the use of a water booster, (82-3401 or MC-163172). Water pressure exceeding 50 PSI (0.345 MPA) must be reduced by way of a water regulator (18-0253/02)
- Use a filter in the water line to avoid equipment damage and beverage off-taste. Check the water filter periodically, as required by local conditions.
- **CAUTION:** The water supply must be protected by means of an air gap, a backflow prevention device (located upstream of the CO<sub>2</sub> injection system) or another approved method to comply with NSF standards. A leaking inlet water check valve will allow carbonated water to flow back through the pump when it is shut off and contaminate the water supply.
- **CAUTION:** Ensure the backflow prevention device complies with ASSE and local standards. It is the responsibility of the installer to ensure compliance.

# SPECIFICATIONS AND FEATURES

## Multi-brand Tower Specifications

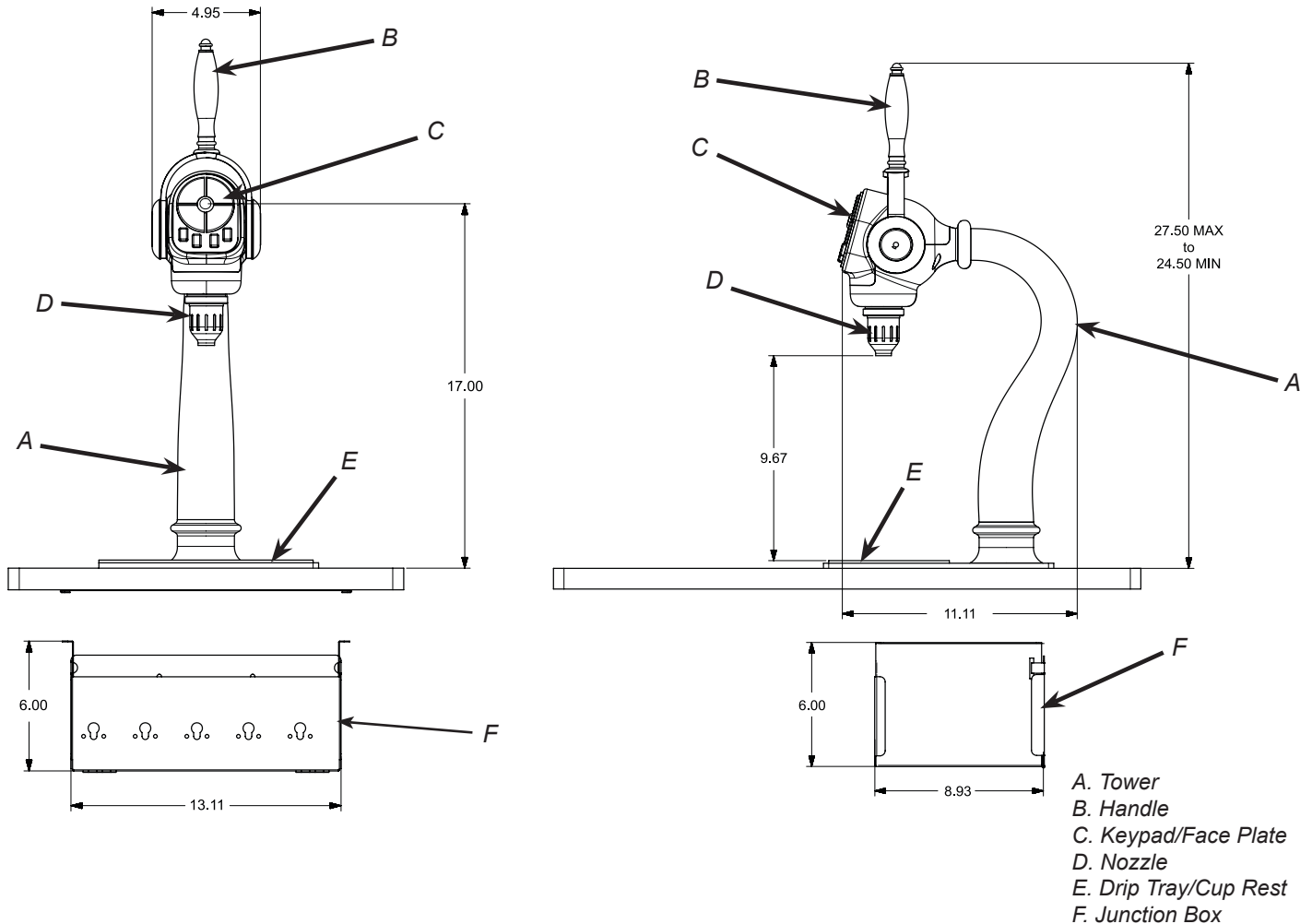

### DIMENSIONS

Width: 4.95 inches (126 mm)  
 Depth: 11.1 inches (282 mm)  
 Height: 25.4 inches (645 mm)

### WEIGHT

Shipping: 35 lbs (15.9 kg)  
 Counter Weight: 40 lbs (18.1 kg)

### NORTH AMERICA ELECTRICAL REQU.

120 VAC / 50/60 Hz

### INTERNATIONAL ELECTRICAL REQU.

Rated 50 VA or higher, primary voltage as required, and a Secondary Voltage 24 VAC. Overcurrent and surge protection is recommended.

### PLAIN WATER SUPPLY

Min Flowing Pressure: 40 PSIG (0.276 MPA)  
 Max Pressure: 110 PSIG (0.756 MPA)

### SYRUP SUPPLY

Min Pressure: 20 PSI (0.137 MPA)  
 Max Pressure: 70 PSI (0.482 MPA)

### DIET SYRUP SUPPLY

Min Pressure: 10 PSIG (0.068 MPA)  
 Max Pressure: 70 PSIG (0.482 MPA)

### FITTINGS

Plain Water/Soda Inlet: 1/4 inch barb  
 Brand Syrup Inlets: 1/4 inch barb

**This unit emits a sound pressure level below 70 dB**

# Single Brand Tower w/ ADA Specifications

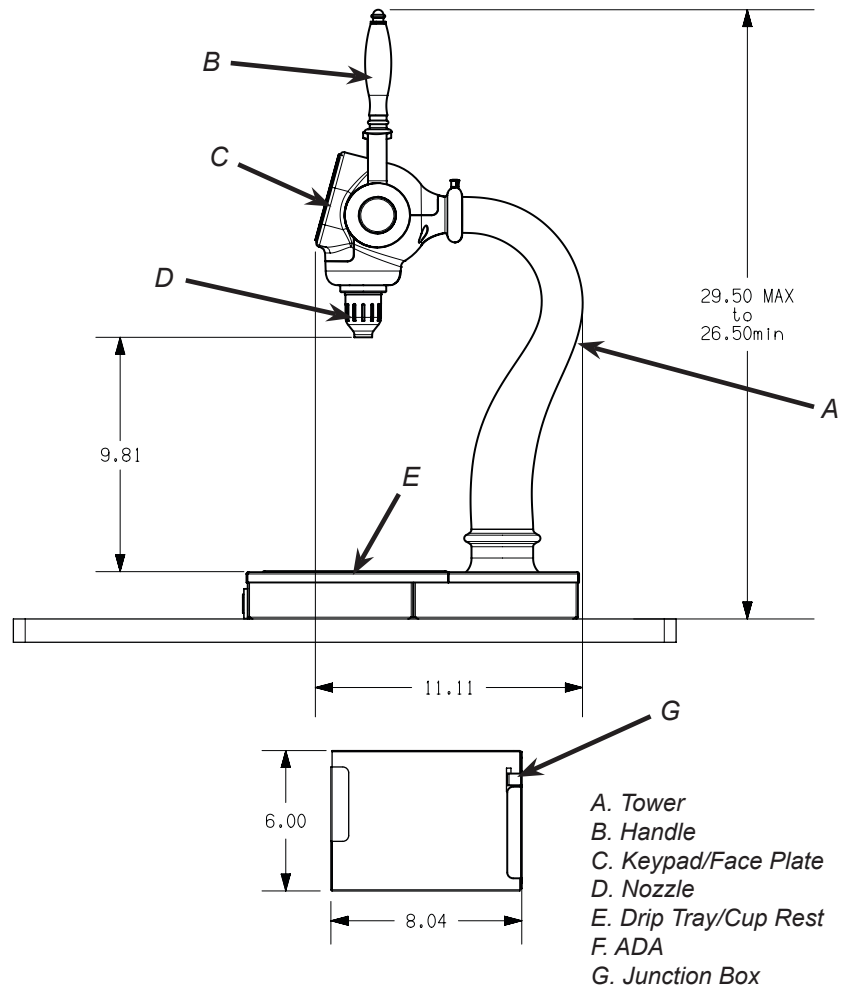
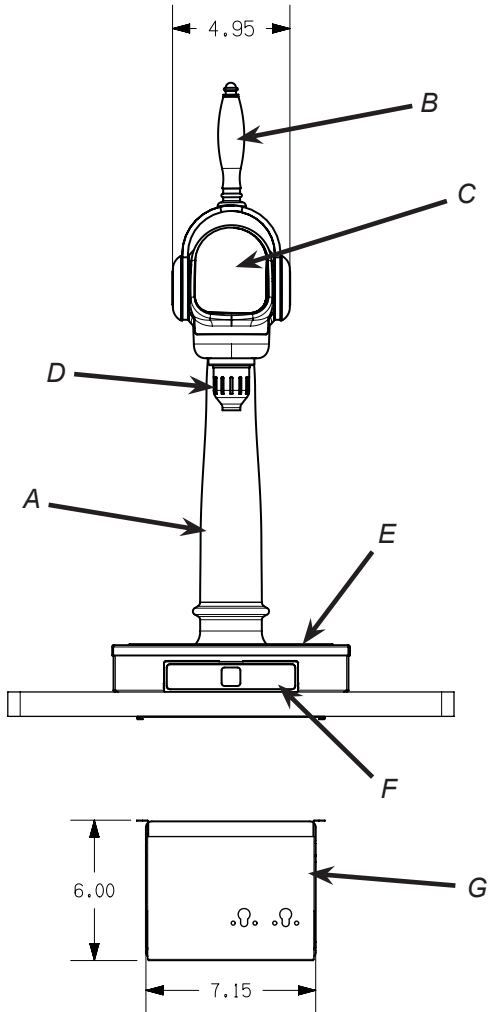

- A. Tower
- B. Handle
- C. Keypad/Face Plate
- D. Nozzle
- E. Drip Tray/Cup Rest
- F. ADA
- G. Junction Box

## DIMENSIONS

*Width:* 4.95 inches (126 mm)  
*Depth:* 11.1 inches (282 mm)  
*Height:* 25.4 inches (645 mm)

## WEIGHT

*Shipping:* 35 lbs (15.9 kg)  
*Counter Weight:* 40 lbs (18.1 kg)

## NORTH AMERICA ELECTRICAL REQU.

120 VAC / 50/60 Hz

## INTERNATIONAL ELECTRICAL REQU.

Rated 50 VA or higher, primary voltage as required, and a Secondary Voltage 24 VAC. Overcurrent and surge protection is recommended.

## PLAIN WATER SUPPLY

*Min Flowing Pressure:* 40 PSIG (0.276 MPA)  
*Max Pressure:* 110 PSIG (0.756 MPA)

## SYRUP SUPPLY

*Min Pressure:* 20 PSI (0.137 MPA)  
*Max Pressure:* 70 PSI (0.482 MPA)

## DIET SYRUP SUPPLY

*Min Pressure:* 10 PSIG (0.068 MPA)  
*Max Pressure:* 70 PSIG (0.482 MPA)

## FITTINGS

*Plain Water/Soda Inlet:* 1/4 inch barb  
*Brand Syrup Inlets:* 1/4 inch barb

**This unit emits a sound pressure level below 70 dB**

## General Systems Overview - Multi-brand Tower

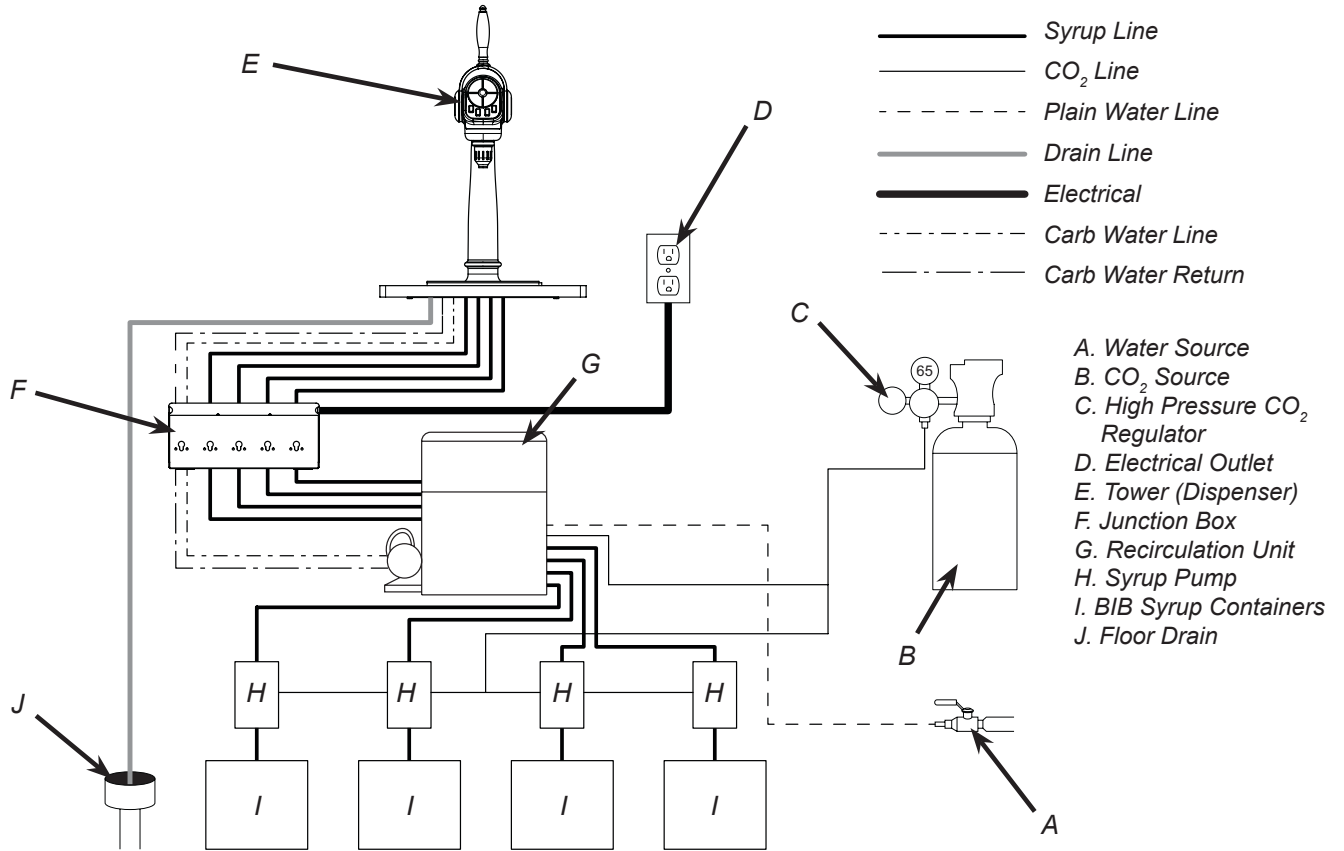

## General Systems Overview - Single Brand Tower

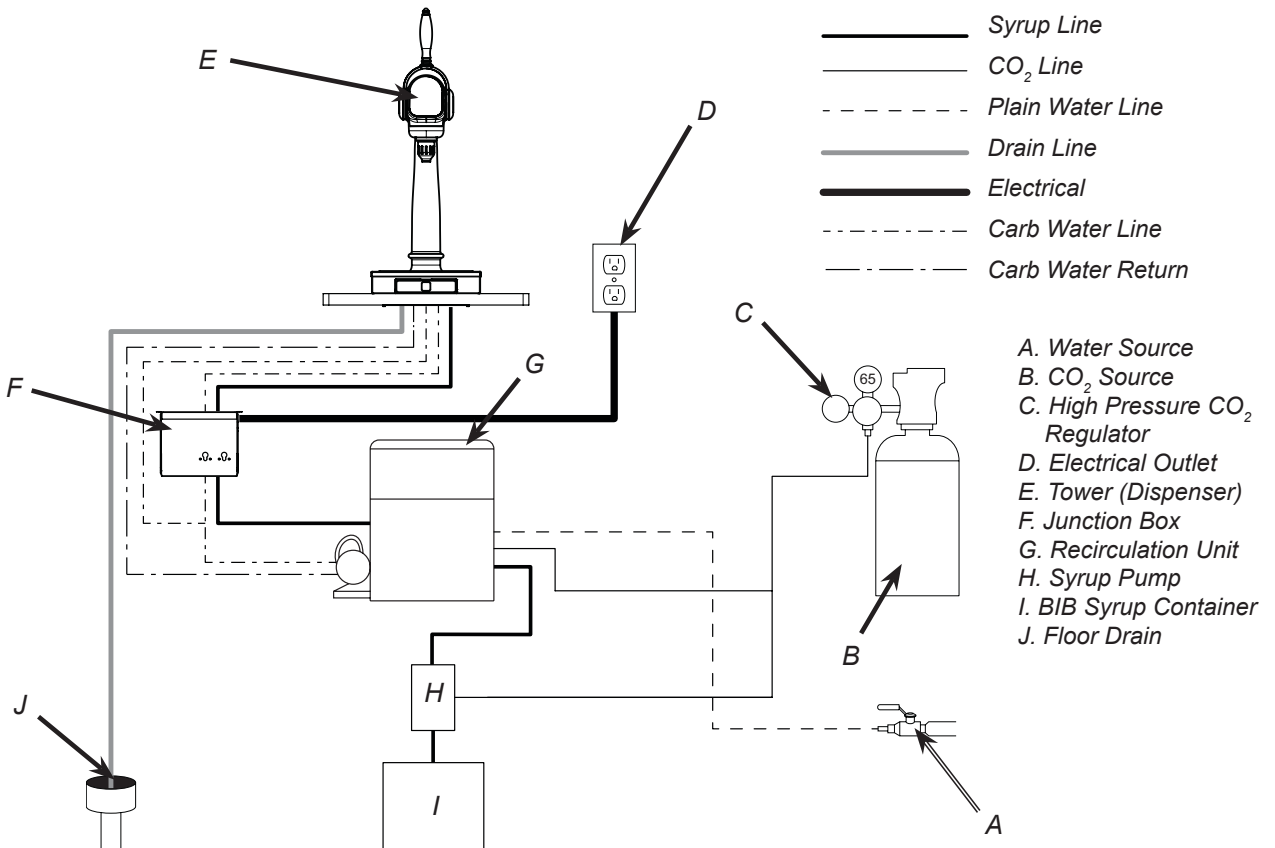

# PRE-INSTALLATION CHECKLIST

## TOOLS REQUIRED:

- Oetiker Pliers
- Tubing Cutters
- Wrench
- Slotted Screwdriver
- Phillips Screwdriver
- Drill

## BIB SYSTEM:

- BIB Rack
- BIB Syrup Boxes
- BIB Regulator Set
- BIB Connectors

## POST MIX ACCESSORIES:

- CO<sub>2</sub> Regulator
- CO<sub>2</sub> Supply
- Chain for CO<sub>2</sub> Tank
- Beverage Dispenser
- Beverage Tubing
- Oetiker Clamp Fittings
- Water Booster (Lancer PN: 82-3401 or MC-163172)
- Water Regulator (recommended)
- Remote Cooling/Carbonation System

## CONSIDER THE FOLLOWING BEFORE INSTALLATION:

- Location of Water Supply Lines
- Location of Drain
- Location of Electrical Outlet
- Location of Heating and Air Conditioning Ducts
- Do you have enough space to install the dispenser and junction box?
- Is countertop level?
- Is countertop at least 1 inch thick?

## THIS MANUAL APPLIES TO THE FOLLOWING UNITS

PART NUMBER	DESCRIPTION
85-3151R-21-11111-00	TOWER, UNICORN, RECIRC, TC, PC, CC, VV-R, GI
85-3151R-21-11111	TOWER, UNICORN, RECIRC, TC, PC, CC, VV-R
85-3151R-20-11111-22	TOWER, UNICORN, TC, PC, CC, VV-R, AUS
85-3161R-21-11111	TOWER, UNICORN, TC, PC, CC, LFCV-R
85-3161R-21-11111-00	TOWER, UNICORN, TC, PC, CC, LFCV-R, GI
85-3161R-21-21222	TOWER, UNICORN, RECIRC, TC, PC, GB.LFCV-R
85-3161R-21-21222-00	TOWER, UNICORN, RECIRC, TC, PC, GB.LFCV-R, GI
85-3161R-21-23222	TOWER, UNICORN, RECIRC, TC, NOPC, GB, LFCV-R*
85-3161R-21-23222-00	TOWER, UNICORN, RECIRC, TC, NOPC, GB, LFCV-R, GI*
85-3161R-21-31332	TOWER, UNICORN, RECIRC, TC, PC, PI, LFCV-R
85-3161R-21-31332-00	TOWER, UNICORN, RECIRC, TC, PC, PI, LFCV-R, GI
85-3161R-20-31332-22	TOWER, UNICORN, RECIRC, T/C, PC, PI, LFCV-R, AUS
85-3161R-12-2204	TOWER, UNICORN, RECIRC, T/C, LFCV, SINGLE

### KEY

TC – Thru Counter  
 R – Recirculation (RECIRC)  
 VV – Uses Volumetric valves

PC – Portion Control  
 AUS – Australia  
 LFCV – Uses LFCV valves

NOPC – Non Portion Control (\*Self serve)  
 GI – No Transformer (International Only)  
 SINGLE – Single Brand Tower

---

# INSTALLATION

## Read This Manual

This manual was developed by Lancer Corporation as a reference guide for the owner/operator and installer of this dispenser. Please read this manual before installation and operation of this dispenser. Please see pages 16-18 for troubleshooting or service assistance. If the service cannot be corrected please call your Service Agent or Lancer Customer Service. Always have your model and serial number available when you call.

## Unpacking the Dispenser

---

1. Cut package banding straps and remove.
2. Open the box and remove the dispenser from the corrugated shipping carton
3. Remove accessory kit and loose parts.

### NOTE

**Inspect unit for concealed damage. If evident, notify delivering carrier and file a claim against the same.**

## Selecting/Preparing a Counter Location

---

1. Select a location that is in close proximity to a properly grounded electrical outlet, within five (5) feet (1.5 m) of a drain, and a water supply that meets the requirements shown in the Specifications section found on pages 4 - 5.
2. Select a location that utilizes the clearances/space required for installation.
3. Select a location for the remote chiller system or carbonator (if necessary), syrup pumps, CO<sub>2</sub> tank, syrup containers, and water filter (recommended).
4. Using Counter Cutout Template provided (See page 29), cut out required openings for the Drip Tray and Tower in the designated location.

### ⚠ ATTENTION

**Inspect the counter location where the unit is to be installed. Verify the selected counter is strong enough to safely support the weight of the installed unit, after the cutout for the unit is made. The ideal counter for installation should measure at least one (1) inch thick.**

### NOTE

**To assure that beverage service is accessible to all customers, Lancer recommends that counter height and equipment selection be planned carefully. The 2010 ADA Standards for Accessible Design states that the maximum reach height from the floor should be no more than 48" if touch point is less than 10" from the front of the counter, or a maximum of 46" if the touch point is more than 10" and less than 27" from the front of the counter. For more information about the customer's legal requirements for the accessibility of installed equipment, refer to 2010 ADA Standards for Accessible Design - <http://www.ada.gov>.**

## Tower Installation - Multi-brand Tower

### NOTE

If Unicorn Tower being installed is a Single Brand Tower with an ADA Panel, skip to next section.

1. Place the drip tray into the counter cutout.
2. Route ribbon cable, harness, and syrup/water lines of the tower through the opening in the drip tray assembly.
3. Guide the tower through the opening in the drip tray and position the tower facing forward, with the nozzle above the drip tray.

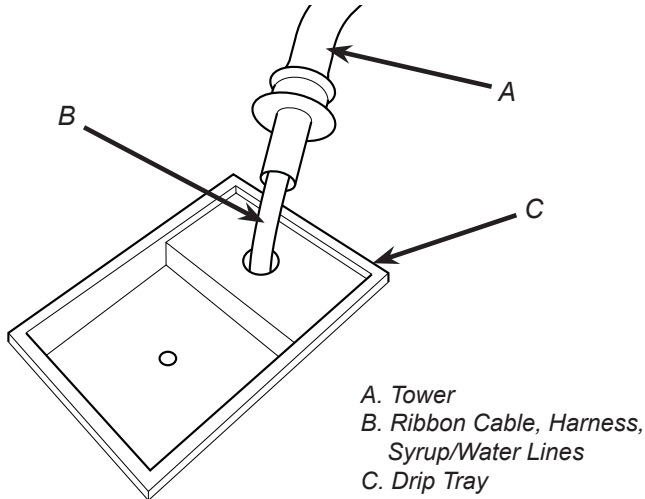

4. Route ribbon cable, harness, and syrup/water lines through the the tower connection nut provided, then thread the nut onto the tower and tighten to secure to counter.

### ⚠ ATTENTION

Do not over tighten, this can cause damage to the ceramic lever.

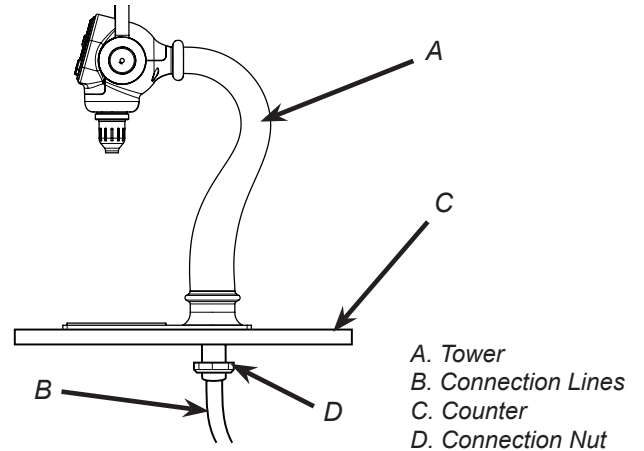

5. Connect drain line to drain fitting at drip train and route to open type drain.

## Tower Installation - Single Brand Tower

1. Plug ADA harness (PN 52-3734) into ADA panel in front of drip tray.
2. Route all harnesses and syrup/water lines of the tower through the opening in the drip tray assembly and through opening in tower collar (PN 05-3491).
3. Place drip tray with collar into counter cutout.
4. Guide the tower through the opening in the drip tray and position the tower facing forward, with the nozzle above the drip tray.

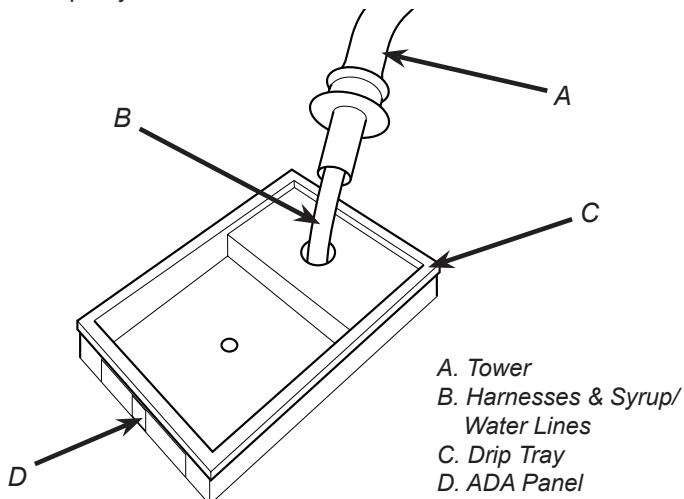

5. Route tower harnesses and syrup/water lines through the the tower connection nut provided, then thread the nut onto the tower and tighten to secure to counter.

### ⚠ ATTENTION

Do not over tighten, this can cause damage to the ceramic lever.

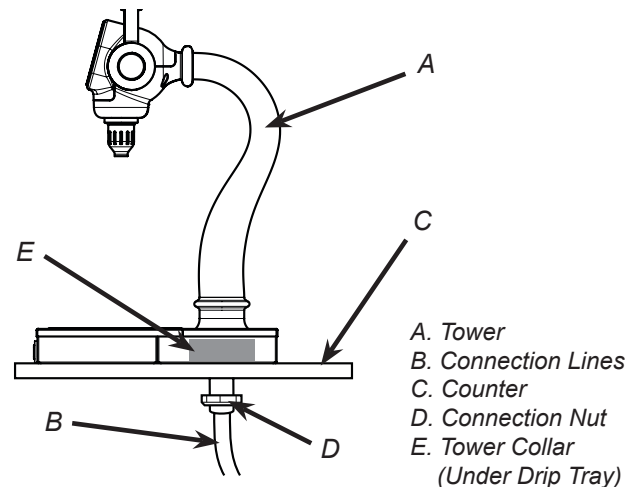

6. Connect drain line to drain fitting at drip tray and route to open type drain.

# Junction Box Installation

## NOTE

Tower harnesses and syrup/water lines are all 36 inches in length. Placement of the Junction Box must be under the counter and within 2 feet (24 inches) of the Tower assembly.

## WARNING

DO NOT install or set junction box on the ground, this is a shock hazard.

1. Position the Mounting Bracket of the Junction Box so that there is adequate slack for connection lines to accommodate sliding the Junction Box forward for service.
2. Secure the Mounting Bracket to bottom of the counter with four screws provided.

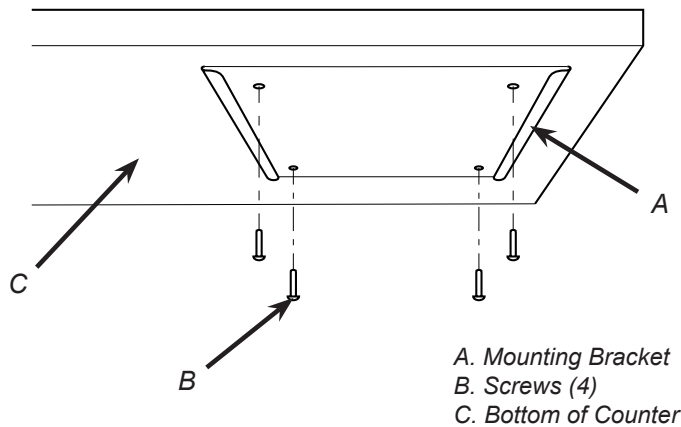

3. Align the Junction Box with the Mounting Bracket, then slide box through bracket to secure to counter.

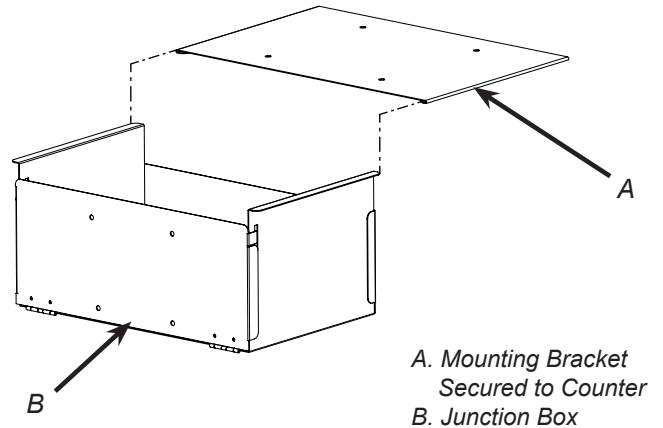

4. If applicable, connect the ADA harness (PN 52-3734), routed from ADA panel in drip tray, to extra connecting wire in Tower harness (PN 52-3732).
5. Connect the power harness (PN 52-3348) to its appropriate connections on the main board in the junction box.

## NOTE

See image below or Wiring Diagram located in Junction Box or on pages 27 and 28 of this manual for reference.

6. For LFCV Models, connect the valve harness (PN 52-3344) and Tower Harness (52-3732) to appropriate connections in Junction Box.
7. For Volumetric Valve Models, Connect the VV KIP Solenoid Harness (PN 52-3359), the VV Solenoid Harness (PN 52-3360), VV Water Harness (PN 52-3361), and VV Ribbon Cable (PN 52-3346) to their appropriate connections on Main Board in Junction Box.

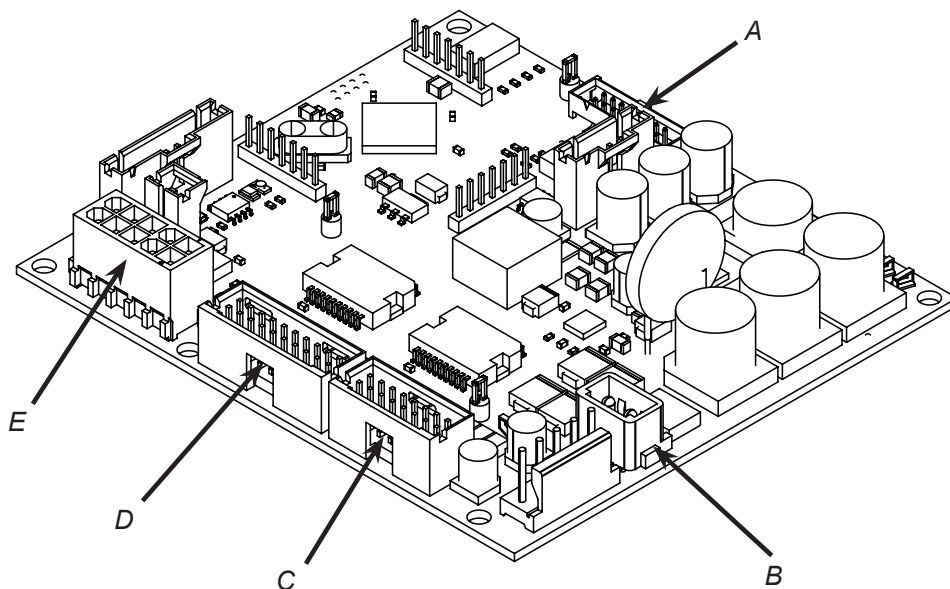

- A. VV Ribbon Cable (52-3346)  
B. Power Harness (52-3348)  
C. LFCV Valve Harness (52-3344)  
- VV KIP Solenoid Harness (52-3359)  
D. VV Solenoid Harness Conn. (52-3360)  
E. Tower Harness (52-3732)  
- VV Water Harness Conn. (52-3361)

# Plumbing Line Connections

## NOTE

Unit is designed to be supported by a remote chiller system or remote ice cooled system. Please see the manufacturer's specifications and instructions for installation. The following are the instructions for plumbing the tower, using the remote chiller system.

1. Route appropriate tubing from the water source to the water inlet at the remote chiller and only connect tubing to the water source. (Refer to Water Notice on page 3)
2. Turn on the water and flush the water line thoroughly.
3. Turn off the water and connect water line to the plain water inlet at the remote chiller.
4. Install filter to water line to avoid equipment damage.

## NOTE

Use a filter of at least 100 mesh [100 strands per 25mm (one inch)] screen and installed immediately upstream of all check valve type backflow preventers used for water supply protection. The screen shall be accessible and removable for cleaning or replacement.

## ⚠ ATTENTION

Check the water filter periodically, as required by local conditions. It is the responsibility of the installer to ensure compliance.

5. Route all syrup and water lines from the tower through the rear of the junction box and connect tubing to appropriate valve outlets.
6. Route appropriate tubing from the syrup outlet at the remote chiller system to the syrup inlet at junction box. Repeat for all syrup connections.

7. Route appropriate tubing from the water outlet at remote chiller to the water inlet at junction box. Repeat for return line.

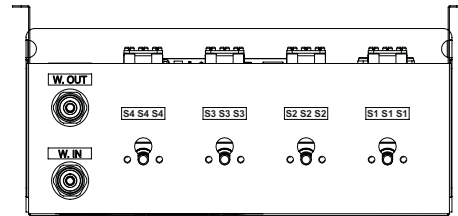

- Multi-brand Tower Junction Box

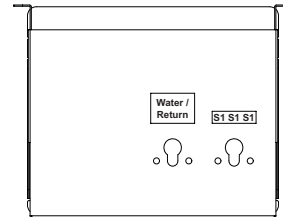

- Single Brand Tower Junction Box

8. Insulate all syrup and water lines accordingly.
9. Once all syrup and water lines are connected and insulated, plug power line into appropriate grounded electrical outlet. (Refer to Power Warnings on page 3)

## ⚠ WARNING

The dispenser must be properly electrically grounded to avoid serious injury or fatal electrical shock. The power cord has a three-prong grounded plug. If a three-hole grounded electrical outlet is not available, use an approved method to ground the unit. Follow all local electrical codes when making connections. Each dispenser must have a separate electrical circuit. Do not use extension cords. Do not connect multiple electrical devices on the same outlet.

## Adjust Water Flow Rate & Syrup/Water Ratio - LFCV

1. Remove nozzle by twisting counterclockwise and pulling down.
2. Install Lancer syrup separator (PN 05-2919) in place of nozzle.
3. Close syrup shut-off at mounting block for syrup brands
4. Using a Lancer ratio cup verify water flow rate (14 oz. in 8 sec.). Use a screwdriver to adjust if needed.

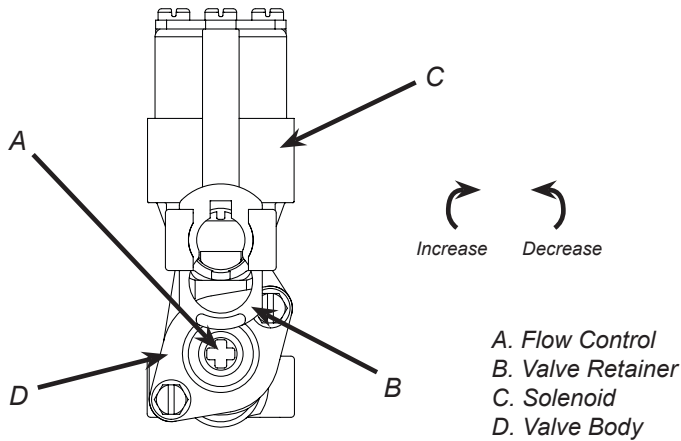

5. Re-open syrup shut-off at mounting block.
6. Using a Lancer ratio cup, activate the valve and capture a sample. Verify that the syrup level is even with the water level. Use a screwdriver to adjust if needed.

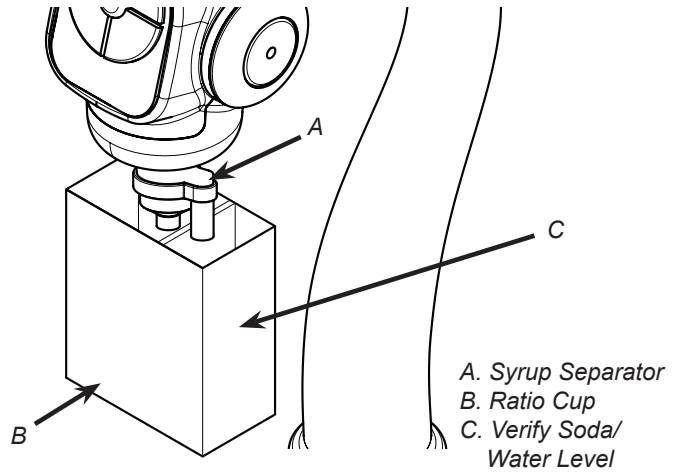

7. Repeat process for each syrup brand.
8. Remove syrup separator and re-install nozzle.

## Volumetric Valve Adjustment

### NOTE

Adjustment of volumetric valves for the Unicorn Tower requires the use of the Volumetric Handheld Programmer and Selector Board (PN 64-5050). The programmer is sold separately for VV programming only.

1. Connect the Volumetric Handheld programmer to the Selector Board.
2. Unplug the unit's Ribbon Cable (52-3346) from the unit's main board, and plug the Selector Board cable in its' place. (See image on previous page or wiring diagram on page 27-28 for reference)

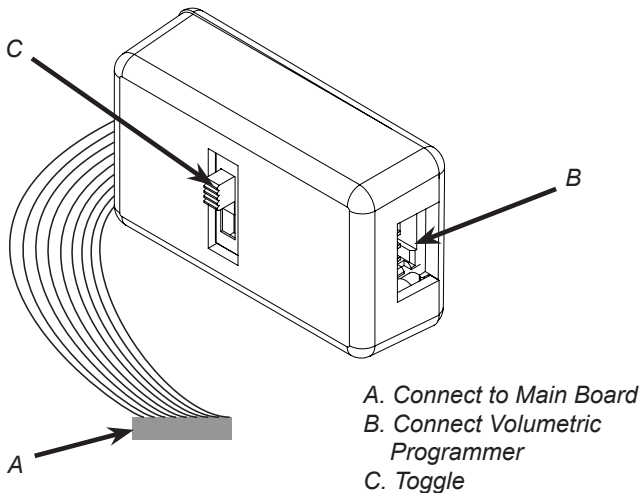

3. Select the valve to program by adjusting the toggle on the Selector Board.

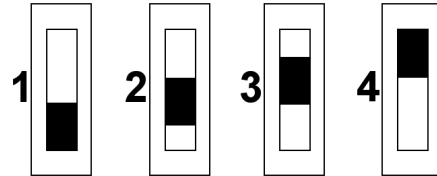

4. Press [red mem] to read the valve ratio setting in memory.
5. Press [carb toggle] button to choose between carbonated (C) or non-carbonated drink (n).



6. Press [+] or [-] to raise or lower desired ratio.
7. Press 'enter' button to save the setting into the valve memory.
8. Repeat Steps 3-7 for the remaining 3 valves, then plug the unit's ribbon cable (52-3346) back into the Main Board.

# PROGRAMMING AND CONFIGURATION

## Programming Overview

### NOTE

The following sections are for Multi-brand units with Volumetric or LFCVs ONLY. Does not apply for Single Brand units.

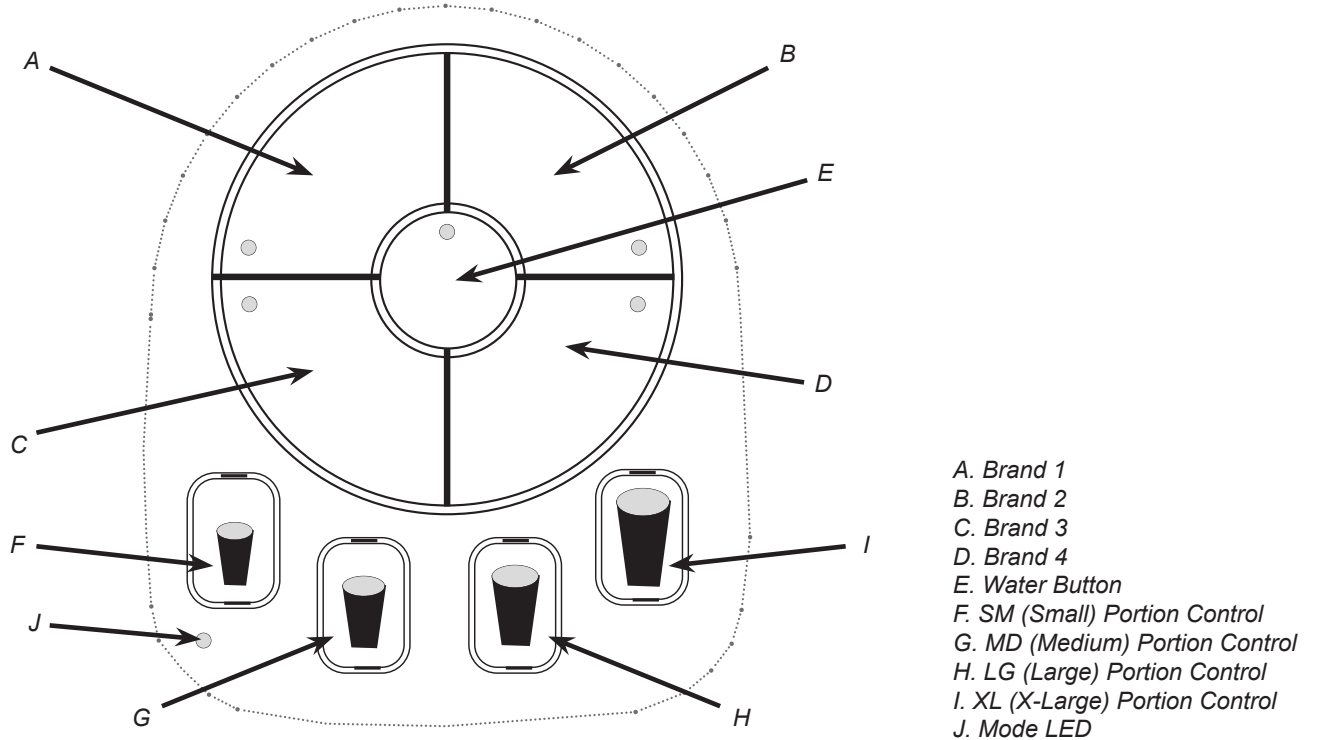

## Valve Configuration

1. On the main board in the junction box, there is a SW1 switch that determines how the valves on the tower work. Any changes to the SW1 switch will cause the dispenser to reset.
2. Leave Toggle 1 in the OFF position for the valves to be in LFCV mode.
3. Switch Toggle 1 to the ON position for the valves to be in Volumetric mode.
4. Switch Toggle 2 to the ON position to enable product to be dispensed by pressing and holding the brand buttons.
5. Leave Toggle 2 in the OFF position to require the use of the handle to dispense product.

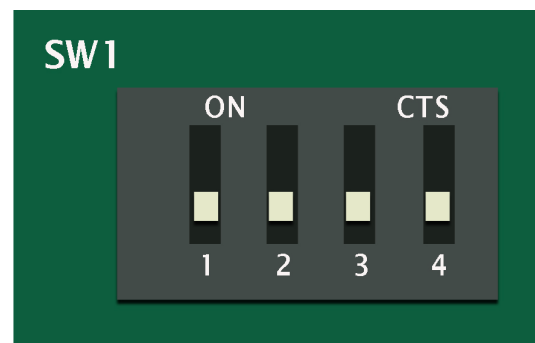

## Purge Mode

### NOTE

**Purge Mode allows independent purging of water or syrup without shutting off the back block.**

1. If unit is in Idle Mode with no Active Brand selected, and has not been dispensed since unit was powered on, the Purge Mode can be accessed by pressing and holding both the Brand 1 and Brand 4 buttons for 5 seconds.
2. During Purge Mode, the Mode LED blinks at a low duty cycle.

3. Press and hold Water Button, to dispense water.
4. Press and hold a Brand Button, to dispense brand syrup only

### NOTE

**The unit will default to Idle Mode automatically, if:**

- the unit is NOT dispensing and inactive for at least 60 (sixty) seconds prior.
- the unit is NOT dispensing and the handle is pulled.

## Timed Pour Mode

### NOTE

**Time Pour Mode can assist in valve flow rate calibration**

1. If unit is in Idle Mode with no Active Brand selected, and has not been dispensed since unit was powered on, the Timed Pour Mode can be accessed by pressing and holding both the Brand 1 and Brand 2 buttons for 5 seconds.
2. During Timed Pour Mode, the Mode LED blinks rapidly.

3. Press Water Button, to dispense water.
4. Press a Brand button, to perform an 8 second timed pour of that selected brand.

### NOTE

**The unit will default to Idle Mode automatically, if:**

- the unit is NOT dispensing and inactive for at least 60 (sixty) seconds prior.
- the unit is NOT dispensing and the handle is pulled.

## Portion Control Programming

1. With the unit in Idle Mode, press a Brand Button to be programmed, then press and hold the SM and XL portion for 5 seconds to access Program Mode.

### NOTE

**During Program Mode and its sub-modes, all dispenses use the Active Brand and the information stored for a Size is only for the Active Brand.**

2. During Program Mode, the Mode LED will blink at a moderate duty cycle.
3. Put desired amount of ice in cup and place the cup under the valve.
4. Press and hold the size to be programmed until cup fills to desired portion.

5. Wait for foam to settle, then press and hold the size button again to top off.
6. Repeat steps 3-5 for a different size then press the active Brand Button to exit portion program mode and save the programmed sizes.
7. Repeat steps 1-6 for remaining brands.

### NOTE

**The unit will default to Idle Mode automatically, if:**

- the unit is NOT dispensing and inactive for at least 60 (sixty) seconds prior.
- the unit is NOT dispensing and the handle is pulled.

### NOTE

**If a topoff is not necessary, return to Step 3 with a different size or press the active Brand Button to exit portion program mode and save the programmed sizes.**

# CLEANING AND SANITIZING

## General Information

- Lancer equipment (new or reconditioned) is shipped from the factory cleaned and sanitized in accordance with NSF guidelines. The operator of the equipment must provide continuous maintenance as required by this manual and/or state and local health department guidelines to ensure proper operation and sanitation requirements are maintained.

### NOTE

The cleaning procedures provided herein pertain to the Lancer equipment identified by this manual. If other equipment is being cleaned, follow the guidelines established by the manufacturer for that equipment.

- Cleaning should be accomplished only by trained personnel. Sanitary gloves are to be used during cleaning operations. Applicable safety precautions must be observed. Instruction warnings on the product being used must be followed.

### ⚠ ATTENTION

- Use sanitary gloves when cleaning the unit and observe all applicable safety precautions.
- DO NOT** use a water jet to clean or sanitize the unit.
- DO NOT** disconnect water lines when cleaning and sanitizing syrup lines, to avoid contamination.
- DO NOT** use strong bleaches or detergents; These can discolor and corrode various materials.
- DO NOT** use metal scrapers, sharp objects, steel wool, scouring pads, abrasives, or solvents on the dispenser.
- DO NOT** use hot water above 140° F (60° C). This can damage the dispenser.
- DO NOT** spill sanitizing solution on any circuit boards. Insure all sanitizing solution is removed from the system.

## Cleaning and Sanitizing Solutions

### Cleaning Solution

Mix a mild, non-abrasive detergent (e.g. Sodium Laureth Sulfate, dish soap) with clean, potable water at a temperature of 90°F to 110°F (32°C to 43°C). The mixture ratio is one ounce of cleaner to two gallons of water. Prepare a minimum of five gallons of cleaning solution. Do not use abrasive cleaners or solvents because they can cause permanent damage to the unit. Ensure rinsing is thorough, using clean, potable water at a temperature of 90°F to 110°F. Extended lengths of product lines may require additional cleaning solution.

### Sanitizing Solution

Prepare sanitizing solutions in accordance with the manufacturer's written recommendations and safety guidelines. The solution must provide 100 parts per million (PPM) chlorine (e.g. Sodium Hypochlorite or bleach). A minimum of five gallons of sanitizing solution should be prepared. Any sanitizing solution may be used as long as it is prepared in accordance with the manufacturer's written recommendations and safety guidelines, and provides 100 parts per million (PPM) chlorine.

## Daily Cleaning

### ⚠ WARNING

Unplug the dispenser before servicing, cleaning, or sanitizing any of the equipment.

- Disconnect power to the unit.
- Mix an appropriate amount of cleaning solution in a clean container, then pour a small portion of the cleaning solution in separate clean container (at least 3 inches deep).
- Remove nozzle by twisting counterclockwise and pulling down.
- Submerge the nozzle in the container with the smaller portion of solution.
- Use a clean cloth soaked in the cleaning solution to clean the tower and all exterior stainless steel surfaces.
- Use the soaked cloth to wipe clean all splash areas.
- Rinse nozzle in warm water then re-install on tower.

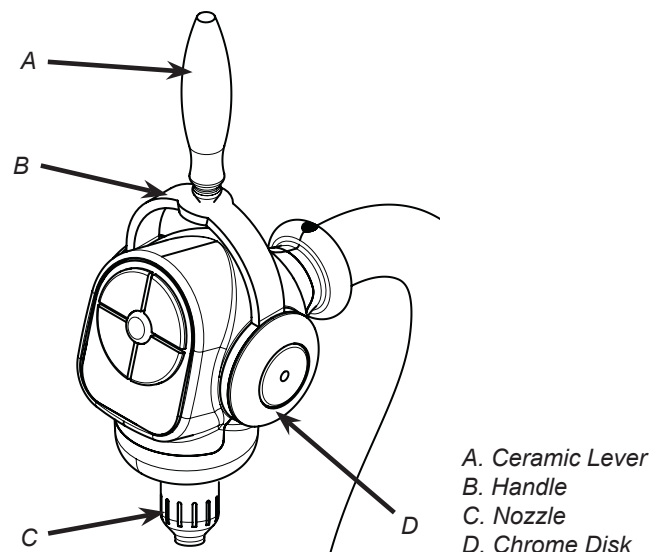

## Weekly Cleaning and Sanitizing

1. Disconnect power to the unit.
2. Mix appropriate amount of cleaning and sanitizing solution in a clean container.
3. Remove nozzle by twisting counterclockwise and pulling down, then submerge the nozzle in the cleaning solution and wipe clean.
4. Submerge the nozzle in the nozzle in the separate sanitizing solution and set aside to air dry
5. Grasp the Chrome Disks located on the right and left side of the dispenser head and rotate, slowly, in a counterclockwise movement until a square notch is visible on both the left and right sides.

### NOTE

When facing unit, the Left Disk will rotate towards the back (away from front) and the Right Disk will rotate forward.

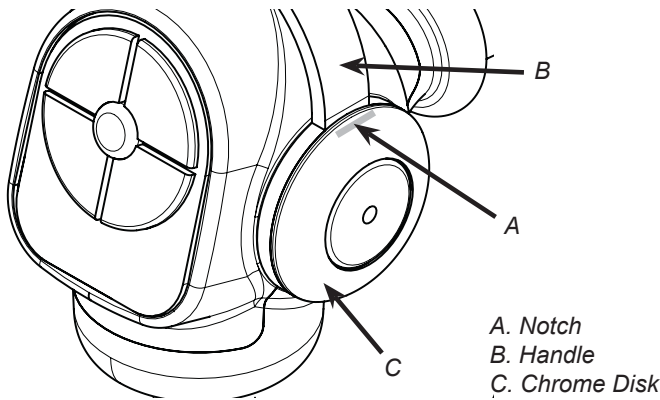

6. Remove the handle by slowly pulling the Handle up and away from the dispensing tower.
7. Use the brush provided (PN 22-0017) to gently clean and sanitize the side of the dispenser head. (Refer to image)

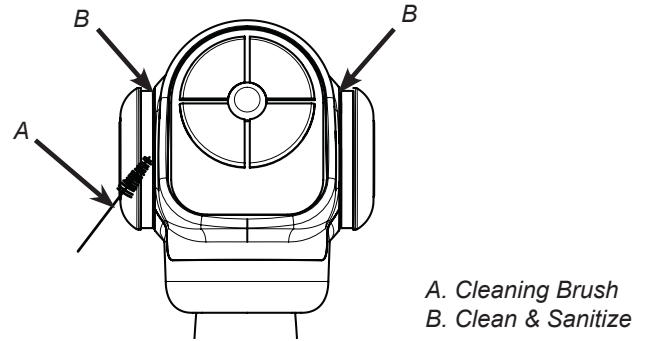

8. Using the cleaning solution, gently clean the handle and ceramic lever.
9. Re-install the handle by aligning the set pins with the notches on both sides of the dispensing tower.
10. Gently push the handle into place then rotate the chrome disks to lock the handle to the tower.

### NOTE

Verify square notches are not visible to prevent accidental handle removal.

11. Remove the cup rest then wipe clean using the cleaning solution.
12. Wipe clean the drip tray using the cleaning solution then replace the cup rest and nozzle
13. Connect power.
14. Taste the drink to verify that there is no off-taste. If off-taste is found, flush syrup system again.

### CAUTION

Following sanitization, rinse with end-use product until there is no aftertaste. Do not use a fresh water rinse. This is a NSF requirement. Residual sanitizing solution left in the system creates a health hazard.

## Cleaning and Sanitizing Syrup Lines - BIB

1. Disconnect syrup lines from BIB's
2. Place syrup lines, with BIB connectors, in a bucket of warm water.
3. Activate each valve to fill the lines with warm water and flush out syrup remaining in the lines.
4. Prepare Cleaning Solution described above.
5. Place syrup lines, with BIB connectors, into cleaning solution.
6. Activate each valve until lines are filled with cleaning solution then let stand for ten (10) minutes.
7. Flush out cleaning solution from the syrup lines using clean, warm water.

8. Prepare Sanitizing Solution described above.
9. Place syrup lines into sanitizing solution and activate each valve to fill lines with sanitizer. Let sit for ten (10) minutes.
10. Reconnect syrup lines to BIB's and draw drinks to flush solution from the dispenser.
11. Taste the drink to verify that there is no off-taste. If off-taste is found, flush syrup system again.

### CAUTION

Following sanitization, rinse with end-use product until there is no aftertaste. Do not use a fresh water rinse. This is a NSF requirement. Residual sanitizing solution left in the system creates a health hazard.

# TROUBLESHOOTING

TROUBLE	CAUSE	REMEDY
Water leakage around nozzle.	1. O-ring is damaged or missing.	1. Replace o-ring.
Miscellaneous leakage.	1. Gap between parts. 2. Damaged or improperly installed o-rings.	1. Tighten appropriate retaining screws 2. Replace or adjust appropriate o-rings
Insufficient water flow.	1. Insufficient incoming supply water pressure. 2. Shutoff on mounting block not fully open. 3. Foreign debris in water flow control. 4. Foreign debris in water pump strainer	1. Verify incoming supply water pressure is a minimum of 25 PSI (0.172 MPA). 2. Open shutoff fully. 3. Remove water flow control from upper body and clean out any foreign material to ensure smooth free spool movement. 4. Remove water pump strainer and clean.
Insufficient syrup flow.	1. Insufficient CO <sub>2</sub> pressure to BIB pumps. 2. Out of CO <sub>2</sub> . 3. Shutoff on mounting block not fully open. 4. Foreign debris in syrup flow control. 5. Bad syrup pump.	1. Adjust CO <sub>2</sub> pressure to 80 PSI (0.550 MPA) [minimum 70 PSI (0.480 MPA)] for BIB pumps. 2. Replace CO <sub>2</sub> tank/refill. 3. Open shutoff fully. 4. Remove syrup flow control form upper body and clean out any foreign material to ensure smooth free spool movement. 5. Replace BIB pump.
Erratic ratio.	1. Incoming water and/or syrup supply not at minimum flowing pressure. 2. Foreign debris in water and/or syrup flow controls. 3. Tolerance of parts affecting ratio. 4. Flowmeter issues.	1. Check pressure and adjust 2. Remove flow controls from upper body and clean out any foreign material to ensure smooth free spool movement. 3. Offset ratio value to obtain optimum dispense ratio. 4. Replace valve body.
No syrup dispensed, only water dispensed	1. Out of syrup 2. Water and syrup shutoffs on mounting block not fully open. 3. Electric current not reaching valve. 4. Improper or inadequate water or syrup supply. 5. Transformer Failure 6. Bad valve solenoid(s) 7. Core seal defective 8. Coil defective	1. Replace BIB. 2. Open shutoff fully. 3. Check electric current supplied to valve. If current is adequate, check solenoid coil and switch, and replace if necessary. 4. Remove valve from mounting block and open shutoffs slightly and check water and syrup flow. If no flow, check dispenser for freeze-up or other problems 5. Reset transformer circuit breaker. If breaker trips again check for pinched wire harness at backblocks 6. Replace Solenoid(s) 7. Replace core seal assembly, if rubber has expanded. 8. Verify connectors are locked into sockets on circuit board OR replace coil if resistance is open or shorted.

TROUBLE	CAUSE	REMEDY
Water only dispensed; no syrup; or syrup only dispensed, no water	<ol style="list-style-type: none"> <li>1. Water or syrup shutoff on mounting block not fully open.</li> <li>2. Improper or inadequate water or syrup flow.</li> <li>3. BIB supply too far from dispenser.</li> <li>4. CO<sub>2</sub> pressure too low.</li> <li>5. Stalled or inoperative BIB pump</li> <li>6. Kinked line.</li> </ol>	<ol style="list-style-type: none"> <li>1. Open shutoff fully.</li> <li>2. Remove valve from mounting block, open shutoffs slightly and check water and syrup flow. If no flow, check dispenser for freeze-up or other problems. Ensure BIB connection is engaged.</li> <li>3. Check that BIB supply is within six (6) feet of the dispenser.</li> <li>4. Check the CO<sub>2</sub> pressure to the pump manifold to ensure it is between 70 and 80 PSI (0.483 and 0.552 MPA).</li> <li>5. Check CO<sub>2</sub> pressure and/or replace pump.</li> <li>6. Remove kink or replace line.</li> </ol>
Syrup only dispensed. No water, but CO <sub>2</sub> gas dispensed with syrup.	<ol style="list-style-type: none"> <li>1. Improper water flow to dispenser.</li> <li>2. Carbonator pump motor has timed out.</li> </ol>	<ol style="list-style-type: none"> <li>1. Check for water flow to dispenser (see Insufficient Water Flow on previous page).</li> <li>2. Reset by turning the unit OFF and then ON.</li> </ol>
Excessive foaming.	<ol style="list-style-type: none"> <li>1. Incoming water or syrup temperature too high.</li> <li>2. CO<sub>2</sub> pressure too high.</li> <li>3. Water flow rate too high.</li> <li>4. Nozzle not installed correctly.</li> <li>5. Nozzle and nozzle injectors not clean.</li> <li>6. Air in BIB lines.</li> <li>7. Poor quality ice.</li> <li>8. High beverage temperature.</li> <li>9. Portion Control not using top-off</li> </ol>	<ol style="list-style-type: none"> <li>1. Correct prior to dispenser. Consider larger dispenser or pre-cooler.</li> <li>2. Adjust CO<sub>2</sub> pressure downward, but not less than 70 PSI (0.483 MPA).</li> <li>3. Re-adjust and reset ratio. Refer to “Adjust Water Flow Rate &amp; Syrup/Water Ratio” Section.</li> <li>4. Remove and reinstall properly.</li> <li>5. Remove nozzle and clean injectors.</li> <li>6. Bleed air from BIB lines.</li> <li>7. Check quality of ice used in drink.</li> <li>8. Check refrigeration system.</li> <li>9. Re-program portion control to include optimum top-off.</li> </ol>
Warm drinks.	<ol style="list-style-type: none"> <li>1. Restricted airflow.</li> <li>2. Dispenser connected to hot water supply.</li> <li>3. Dispenser capacity exceeded.</li> </ol>	<ol style="list-style-type: none"> <li>1. Check clearances around sides, top, and inlet of unit. Remove objects blocking airflow through grill.</li> <li>2. Switch to cold water supply.</li> <li>3. Add pre-cooler or replace with larger dispenser.</li> </ol>
Delayed water Shut-off	<ol style="list-style-type: none"> <li>1. Suction between core and plug nut</li> </ol>	<ol style="list-style-type: none"> <li>1. Replace water plug nut with vented design.</li> </ol>

TROUBLE	CAUSE	REMEDY
Circuit breaker tripping.	<ol style="list-style-type: none"> <li>1. Valve wire harness shorted to itself or to faucet plate.</li> <li>2. PCB is bad.</li> <li>3. Secondary wire harness is bad.</li> <li>4. Transformer failure.</li> </ol>	<ol style="list-style-type: none"> <li>1. Detect short by disconnecting input fasten to keylock and single pin connector. Restore power if breaker doesn't trip. Then valve wire harness is shorted. If OK, reconnect.</li> <li>2. Detect short by disconnecting J1 connector (24 VAC input) from PCB. Restore power, if breaker doesn't trip. Then replace PCB. If breaker does trip, then PCB is OK. Reconnect J1 connector.</li> <li>3. If it does not trip, locate short in secondary harness between transformer, PCB, and valve wire harness.</li> <li>4. Detect short by disconnecting both transformerfastons and restore power. If breaker does trip, replace transformer.</li> </ol>
BIB pump does not operate when dispensing valve opened.	<ol style="list-style-type: none"> <li>1. Out of CO<sub>2</sub>, CO<sub>2</sub> not turned on, or low CO<sub>2</sub> pressure.</li> <li>2. Out of syrup.</li> <li>3. BIB connector not tight.</li> <li>4. Kinks in syrup or gas lines.</li> <li>5. Bad BIB Pumps.</li> </ol>	<ol style="list-style-type: none"> <li>1. Replace CO<sub>2</sub> supply, turn on CO<sub>2</sub> supply, or adjust CO<sub>2</sub> pressure to 70-80 PSI (0.483-0.552 MPA)</li> <li>2. Replace syrup supply.</li> <li>3. Fasten connector tightly.</li> <li>4. Straighten or replace lines.</li> <li>5. Replace BIB pump.</li> </ol>
BIB pump operated, but no flow.	<ol style="list-style-type: none"> <li>1. Leak in syrup inlet or outlet line.</li> <li>2. Defective BIB pump check valve.</li> </ol>	<ol style="list-style-type: none"> <li>1. Replace line.</li> <li>2. Replace BIB pump</li> </ol>
BIB pump continues to operate when bag is empty.	<ol style="list-style-type: none"> <li>1. Leak in suction line.</li> <li>2. Leaking o-ring on pump inlet fitting.</li> </ol>	<ol style="list-style-type: none"> <li>1. Replace line.</li> <li>2. Replace o-ring.</li> </ol>
BIB pump fails to restart after bag replacement.	<ol style="list-style-type: none"> <li>1. BIB connector not on tight.</li> <li>2. BIB connector is stopped up.</li> <li>3. Kinks in syrup line</li> <li>4. Bad BIB Pumps.</li> </ol>	<ol style="list-style-type: none"> <li>1. Tighten BIB connector.</li> <li>2. Clean out or replace BIB connector.</li> <li>3. Straighten or replace line.</li> <li>4. Replace BIB pump.</li> </ol>
BIB pump fails to restart when dispensing valve is closed.	<ol style="list-style-type: none"> <li>1. Leak in discharge line or fittings.</li> <li>2. Empty BIB.</li> <li>3. Air leak on inlet line or bag connector.</li> </ol>	<ol style="list-style-type: none"> <li>1. Repair or replace discharge</li> <li>2. Replace BIB.</li> <li>3. Repair or replace.</li> </ol>
Low or no carbonation.	<ol style="list-style-type: none"> <li>1. Low or no CO<sub>2</sub>.</li> <li>2. Excessive water pressure.</li> <li>3. Worn or defective carbonator pump.</li> </ol>	<ol style="list-style-type: none"> <li>1. Check CO<sub>2</sub> supply. Adjust CO<sub>2</sub> pressure to 70 PSI (0.483 MPA).</li> <li>2. Water regulator should be set at 50 PSI (0.345 MPA)</li> <li>3. Replace carbonator pump.</li> </ol>

## Dispenser Disposal

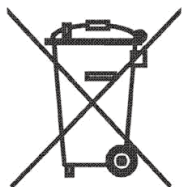

To prevent possible harm to the environment from improper disposal, recycle the unit by locating an authorized recycler or contact the retailer where the product was purchased. Comply with local regulations regarding disposal of the refrigerant and insulation.

# ILLUSTRATIONS AND PART LISTINGS

## Electronics Board - LFCV

<u>Item</u>	<u>Part No.</u>	<u>Description</u>
01	52-3732	Harness, Main Controller, Unicorn
02	52-3344	Harness, LFCV, Thru-Central Valve, Unicorn
03	52-3358	Harness, Bypass, Unicorn
04	64-5048	PCB Assembly, Main Board, Unicorn
05	05-1678	Standoff, PCB, Rev Locking
06	52-3734	Harness, ADA Switch to PCB, Single Brand

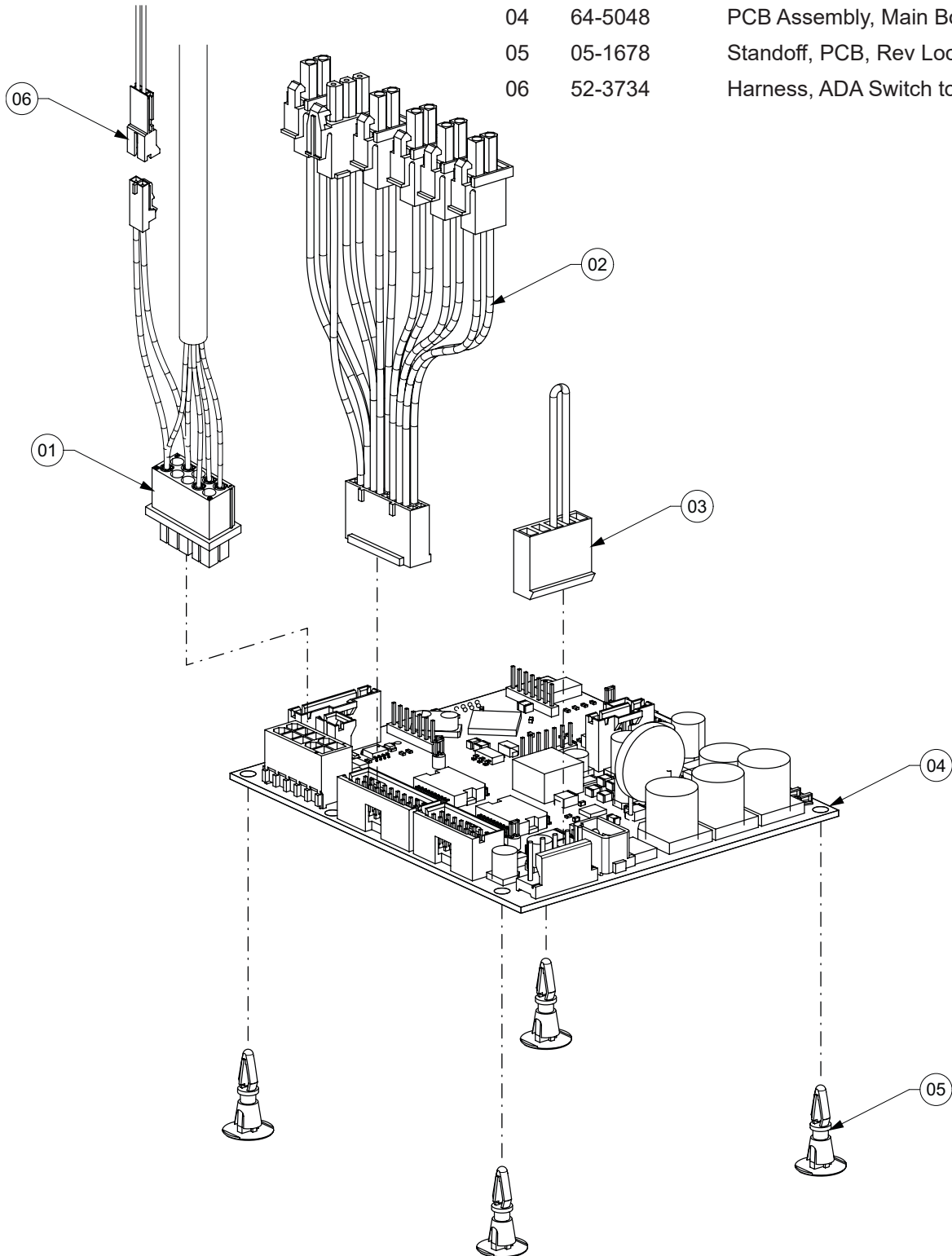

# Electronics Board - VV

<b>Item</b>	<b>Part No.</b>	<b>Description</b>
01	52-3381	Harness, Water Module, VV, Recirc, Unicorn
02	52-3359	Harness, Solenoid, KIP, VV, Unicorn
03	52-3360	Harness, Solenoids VV, Unicorn
04	52-3358	Harness, Bypass, Unicorn
05	64-5048/02	PCB Assembly, Main Board, Unicorn
06	05-1678	Standoff, PCB, Rev Locking

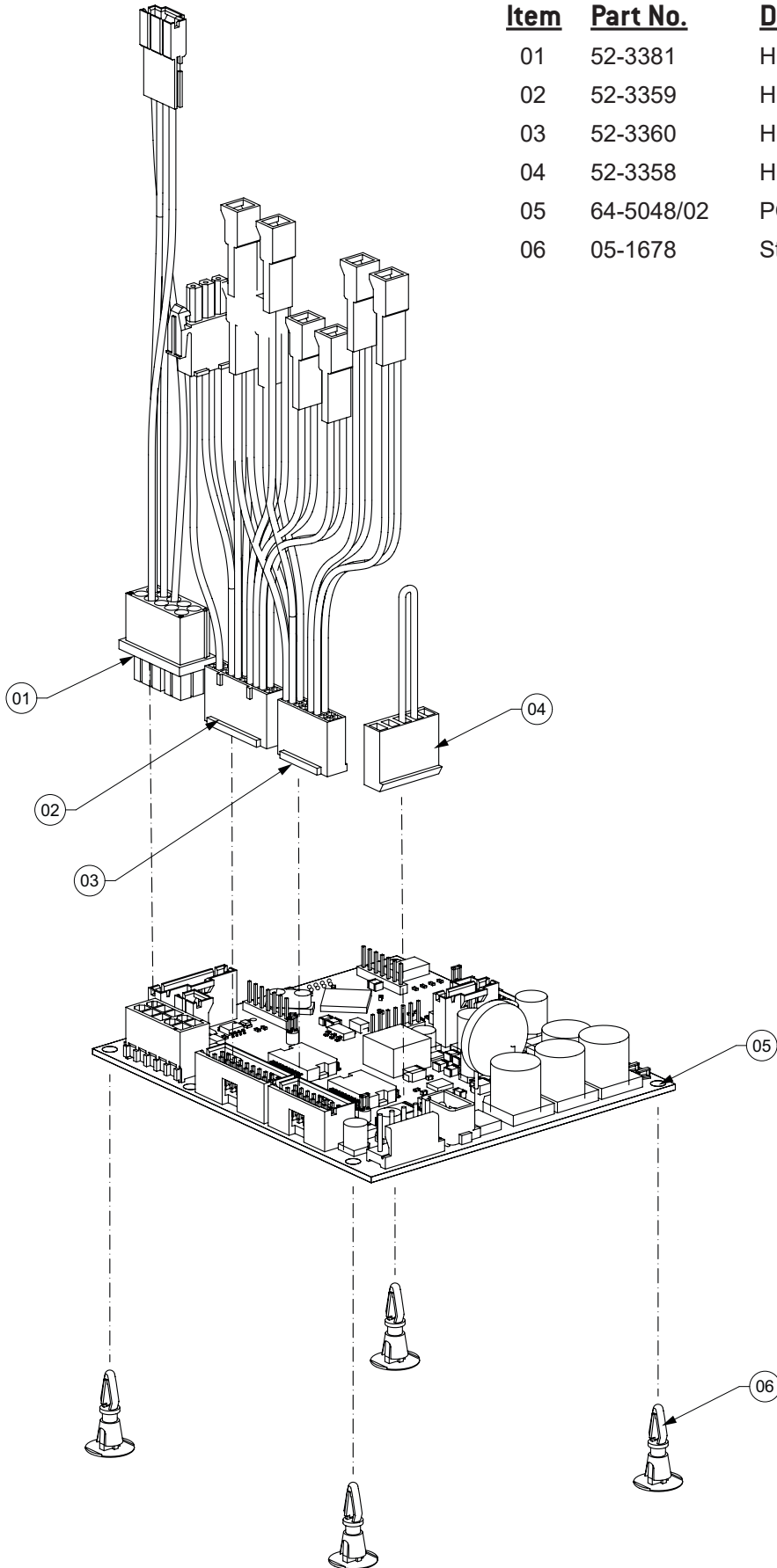

# Nozzle Assembly - LFCV

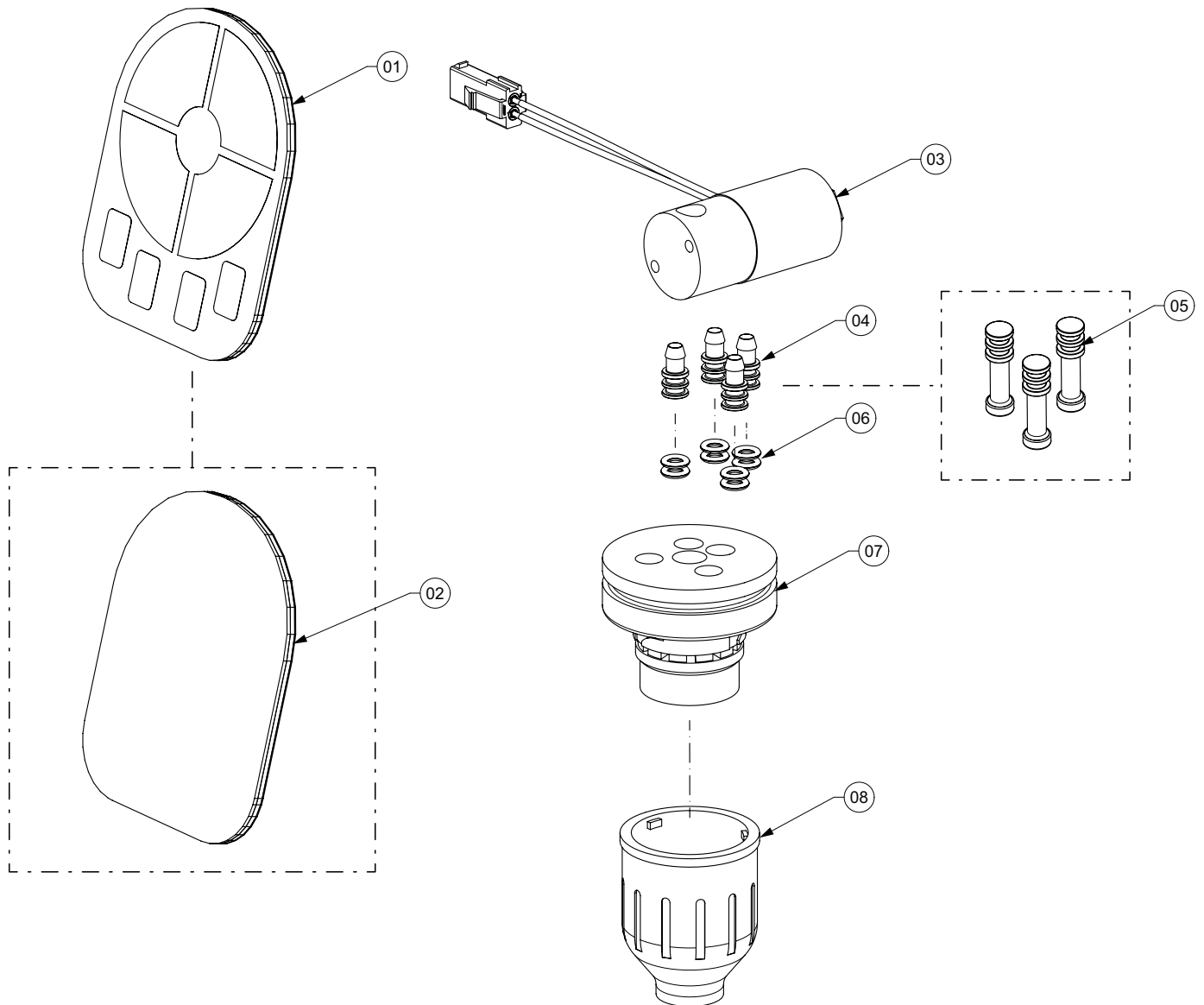

<b>Item</b>	<b>Part No.</b>	<b>Description</b>
01	64-5057	PCB Assembly, Touch Pad, Unicorn, w/ Portion Control
02	05-3475	Single Brand Blank Plate (Used only with Single Brand Unicorn Tower, 85-3161R-12-2204)
03	17-0647/01	Solenoid, 24 VDC, 1/8 NPT, 2 WNC
04	05-2971	Elbow, Quick Connect, 1/4 x 1/8
05	05-1736	Body Plug (Used only with Single Brand Unicorn Tower, 85-3161R-12-2204)
06	02-0214	O-Ring, 2-008, 97-0999
07	81-0679	Nozzle Assembly, Unicorn
08	05-2956	Nozzle, Unicorn, Black
-	05-2943	Nozzle, Unicorn, Red

# Nozzle Assembly - VV

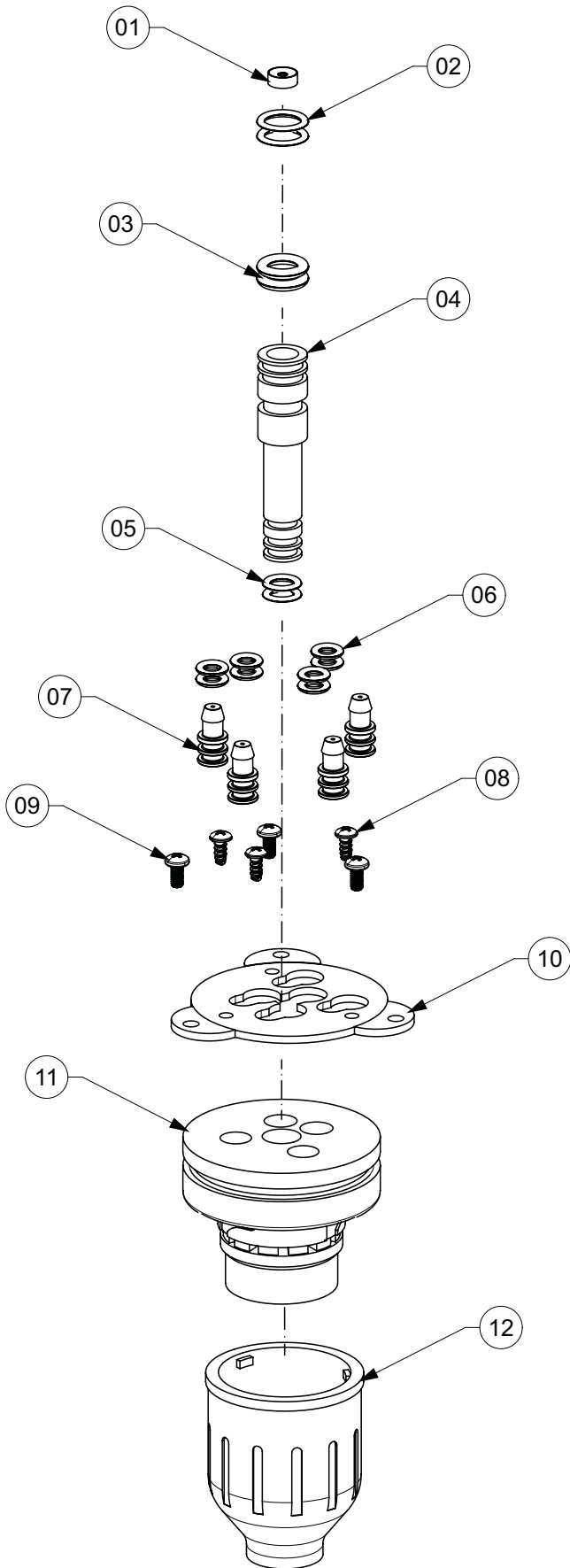

<u>Item</u>	<u>Part No.</u>	<u>Description</u>
01	02-0371	Washer, Flow, 1.5, Vol Valve
02	02-0089	O-Ring, 2-012, 97-0999
03	02-0126	O-Ring, 2-109, 97-0999
04	01-2762	Fitting, Soda Outlet, Unicorn
05	02-0005	O-Ring, 2-010, 97-0999
06	02-0214	O-Ring, 2-008, 97-0999
07	05-2929	Fitting, Inlet, Nozzle, Syrup
08	04-1639	Screw, 4-20X.250 IN, PH, Phillips, Plastite, 18-8 Ss
09	04-1640	Screw, M3x6mm, PH, PH, 6H, S, ZP
10	30-10867	Plate, Mntg, Nozzle, Unicorn
11	81-0679	Nozzle Assembly, Unicorn
12	05-2956	Nozzle, Unicorn, Black
-	05-2943	Nozzle, Unicorn, Red

# LFCV Spare Parts

<u>Item</u>	<u>Part No.</u>	<u>Description</u>
01	01-2884	Fitting, JG, 3/8 X 1/4, Reducer, S/Fit
02	01-2806	JG Bulkhead Connector, 3/8 S/Fit X 3/8 S/Fit
03	19-0267/02	Valve Assembly, LFCV, 2.0 Soda, Gray, S
04	05-1385	Elbow, .5 Dole X .2 Barb, Pls
05	02-0089	O-Ring, 2-012, 97-0999
06	19-0266/02	Valve Assembly, LFCV, 2.0 Syrup, Black, SC
07	04-1089	Screw, 10-32, RH, PH/SI, 1.000
08	82-2317/01	Block, Mounting Assembly, SGL
09	02-0005	O-Ring , 2 -010, 97-0999
10	01-0012	Adaptor, 1/4 Barb X Dole

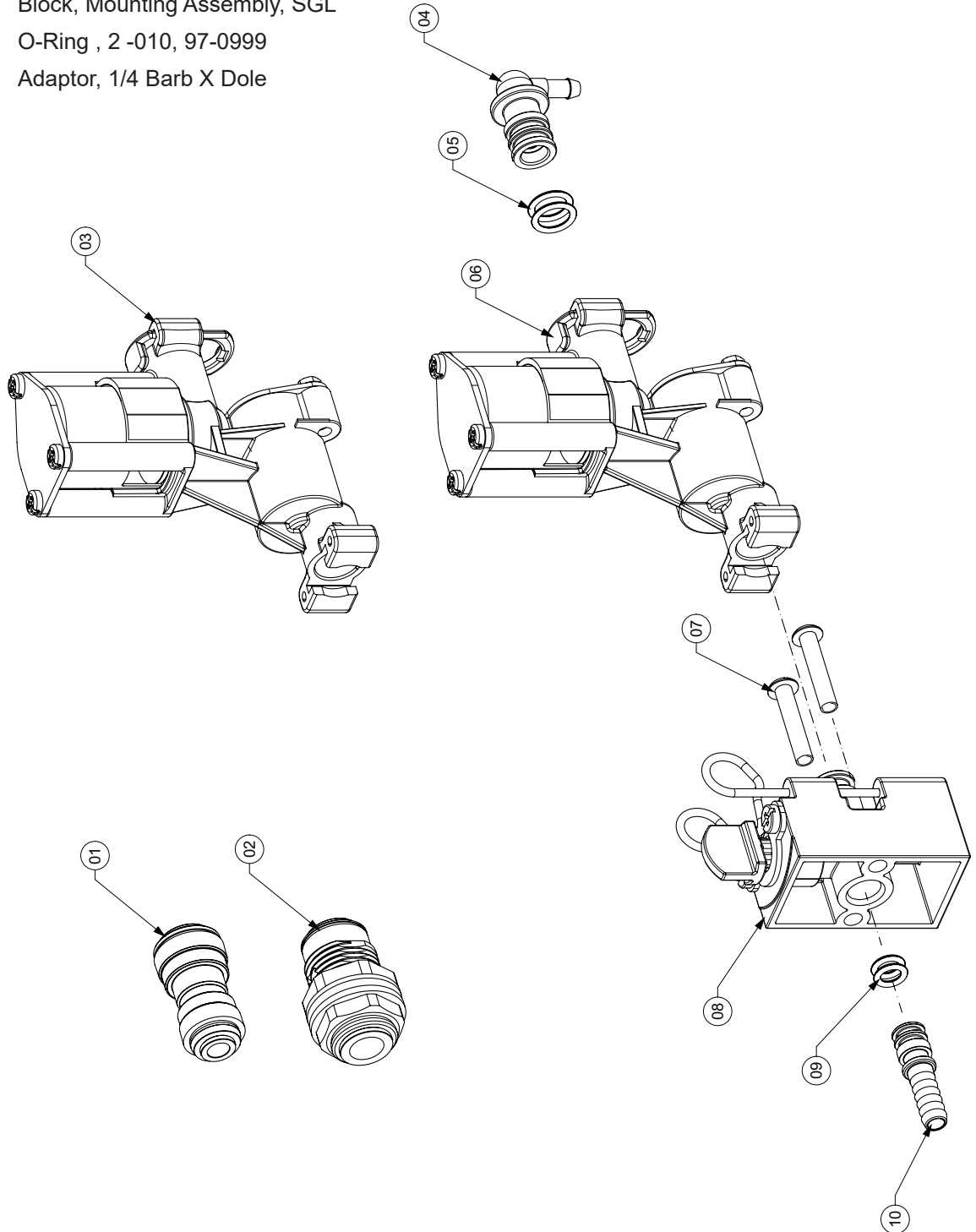

# Water Valve, Volumetric Valve Spare Parts

<u>Item</u>	<u>Part No.</u>	<u>Description</u>
01	05-1385	Elbow, .5 Dole X .2 Barb, PLS
02	02-0089	O-Ring, 2-012, 97-0999
03	19-0399	Water Module, Vol, 1.5 - 3.0
04	05-0967	Retainer, Sol Vlv, Ball Vlv, Premia
05	02-0005	O-Ring , 2 -010, 97-0999
06	05-1386	Elbow, .375 Dole X .2 Barb, PLS
07	19-0398	Syrup Module, Vol, 1.5 - 3.0
08	04-1089	Screw, 10-32, RH, PH/SL, 1.000
09	82-2317/01	Mounting Block Assembly, Single
10	01-0012	Adaptor, 1/4 Barb X Dole
11	04-0527	Cap, Protective, 5 Hip, 1/4 Barb

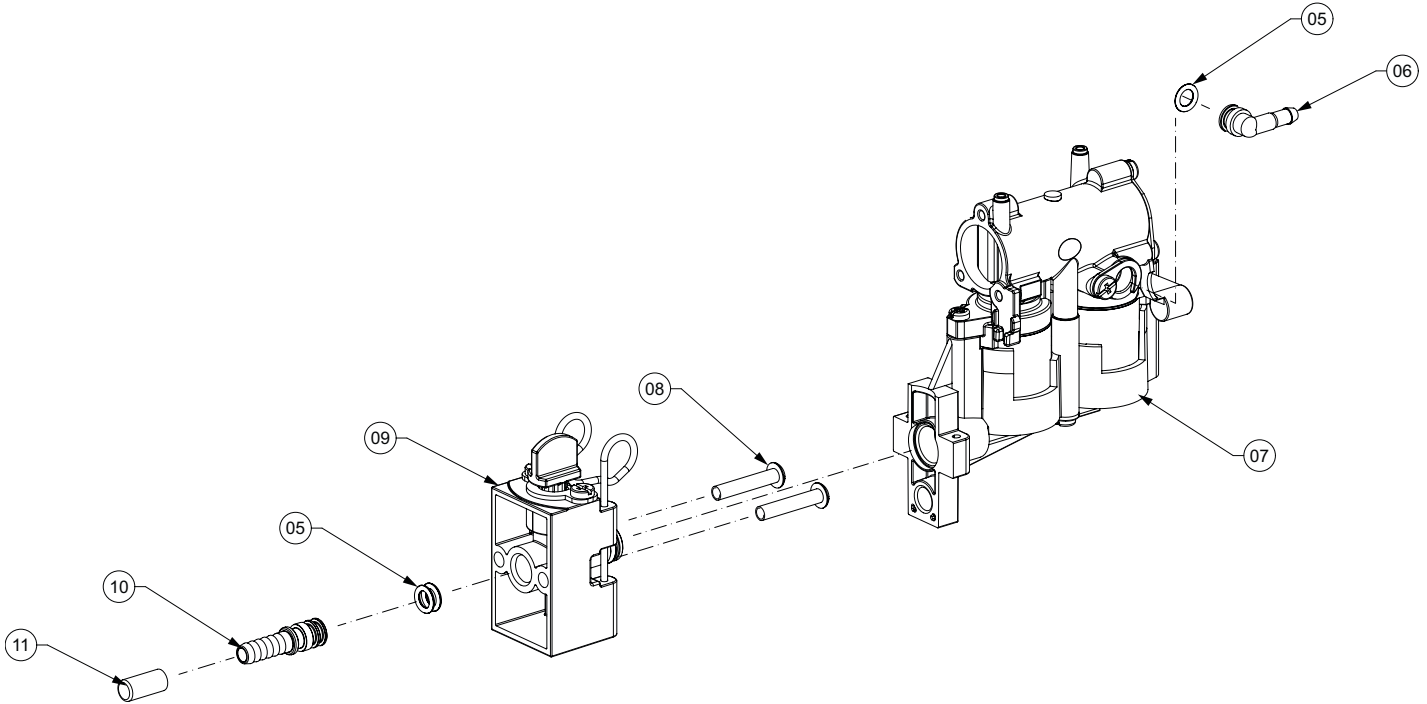
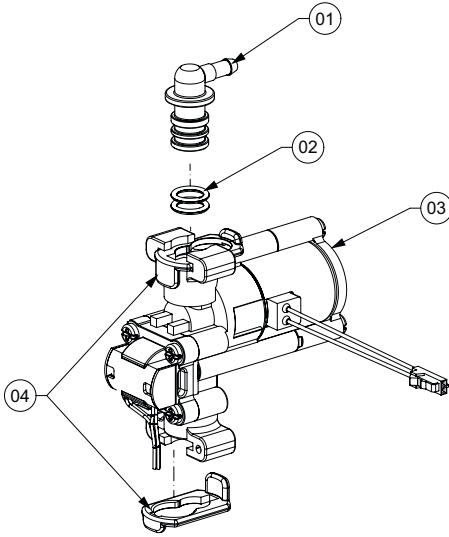

## Misc. Spare Parts

<u>Item</u>	<u>Part No.</u>	<u>Description</u>
01	64-5057	PCB Assembly, Touch Pad, Unicorn, W/Portion Control
02	01-2757	Fitting, Wye, .12I d, Unicorn
03	01-2806	Jg Bulkhead Connector, 3/8 S/Fit X 3/8 S/Fit, 79000217
04	05-3475	Single Brand Blank Plate (Used only with Single Brand Unicorn Tower, 85-3161R-12-2204)

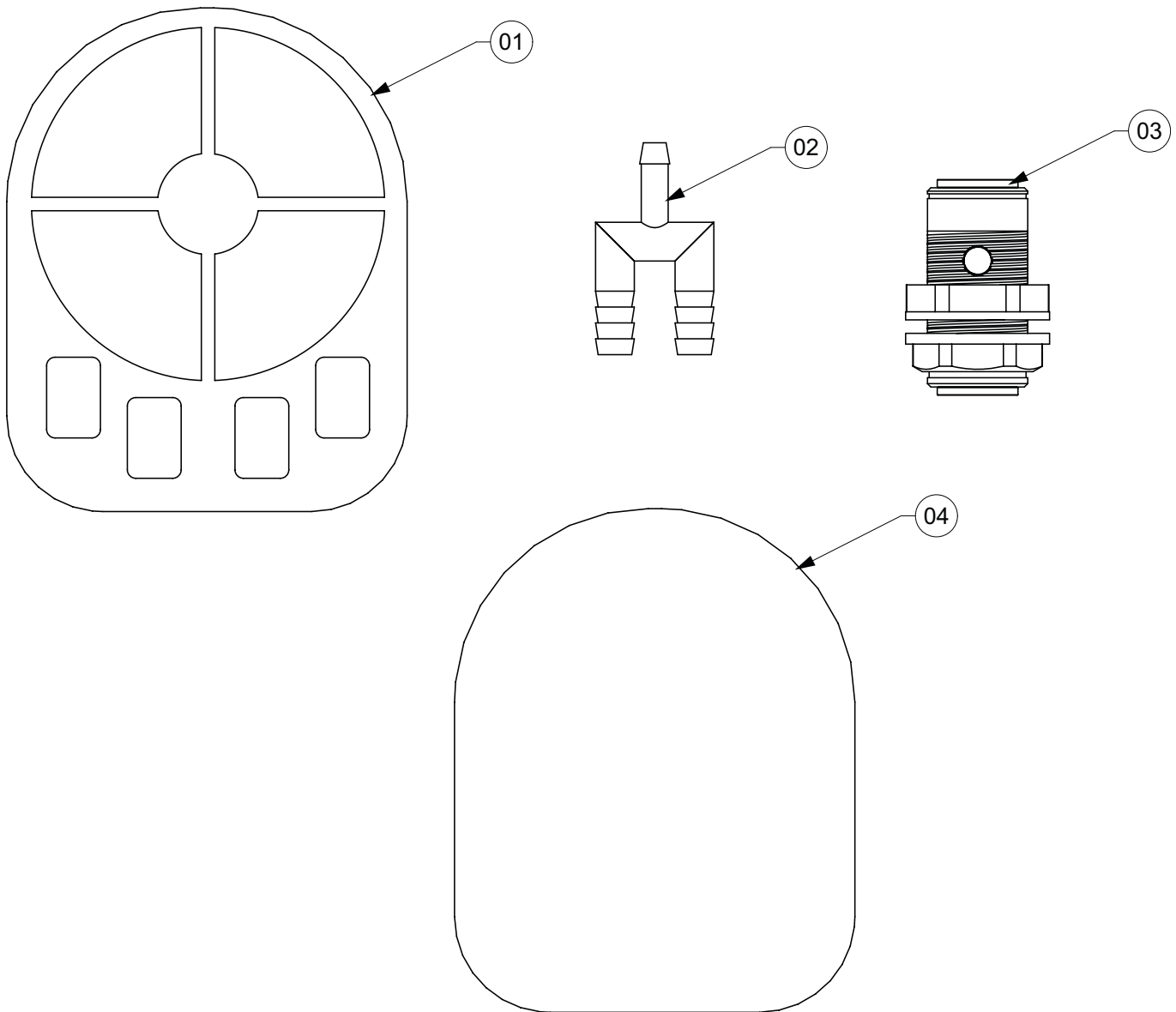

# Wiring Diagram - LFCV

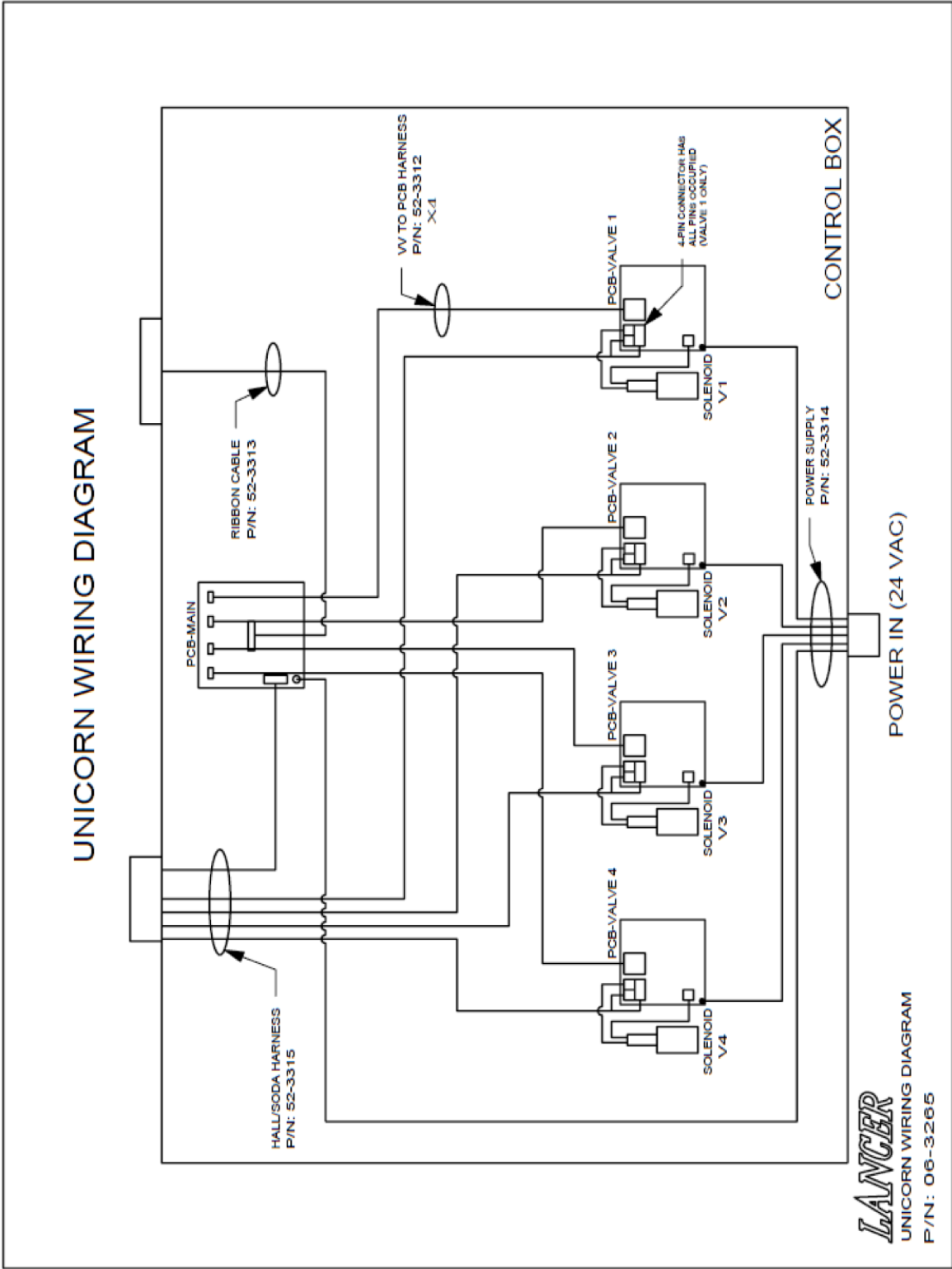

# Wiring Diagram - VV

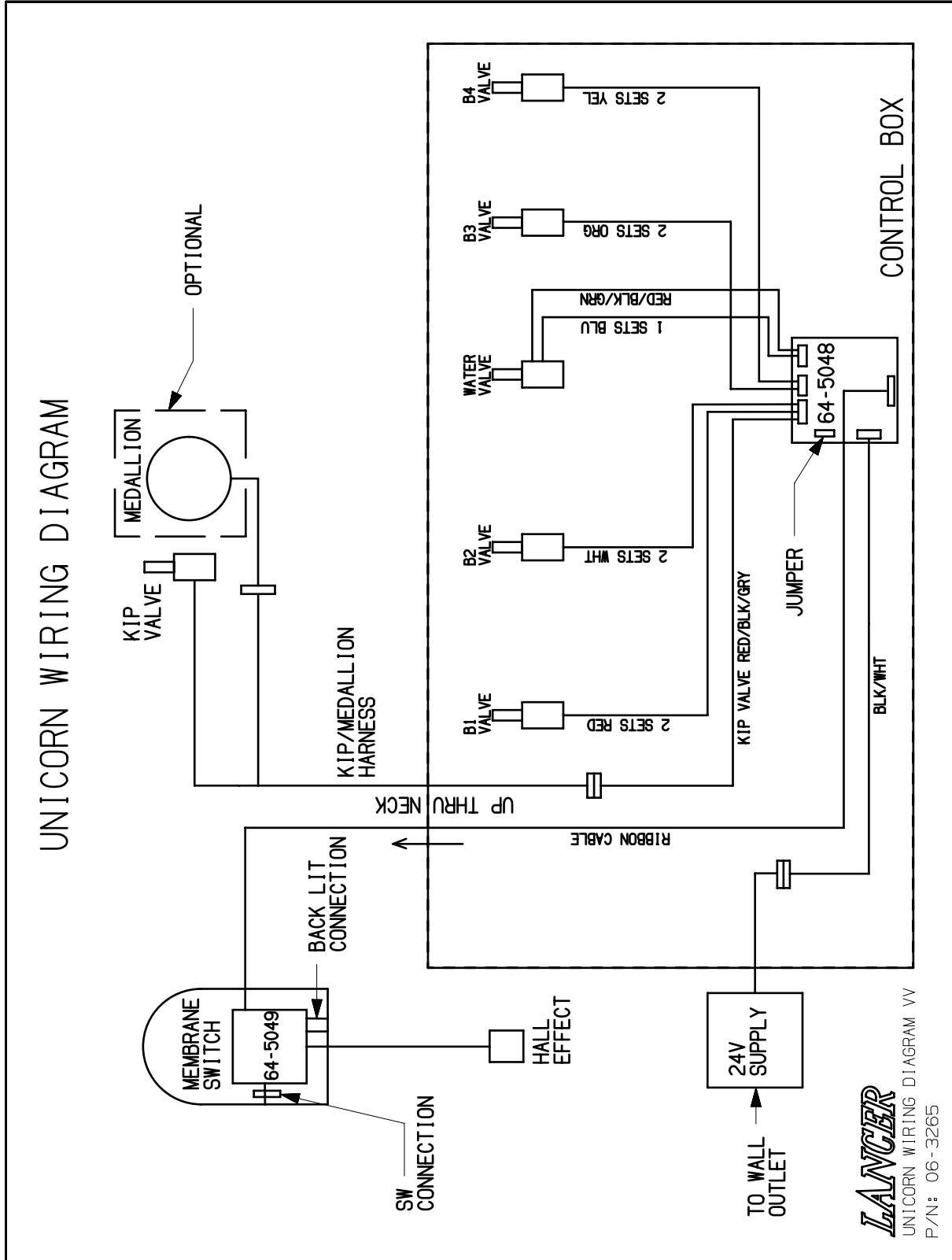

# Counter Cutout (Not to Scale)

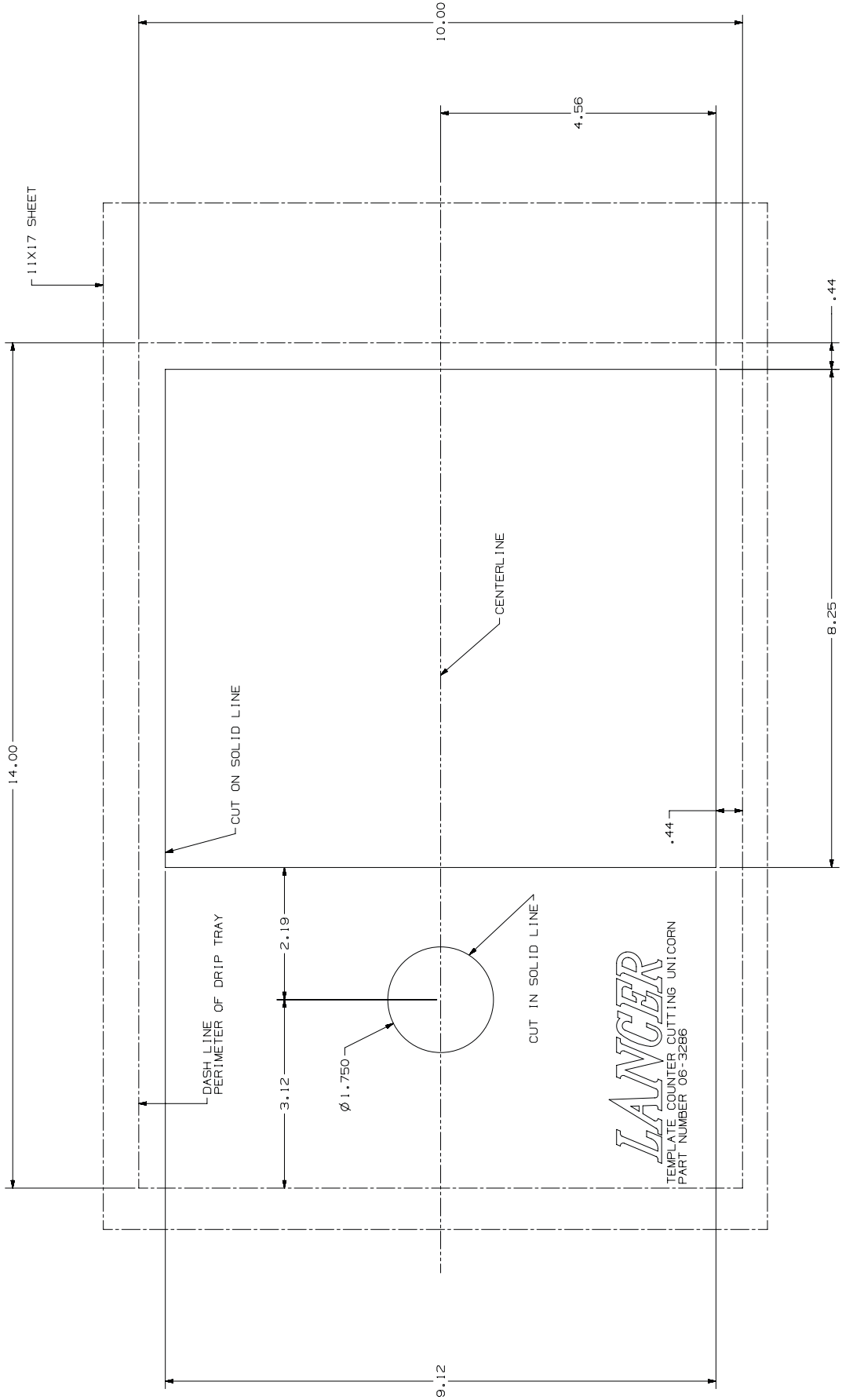

---

***LANCER***<sup>®</sup>

Lancer Corp.

800-729-1500

Technical Support/Warranty: 800-729-1550

[custserv@lancercorp.com](mailto:custserv@lancercorp.com)

[lancercorp.com](http://lancercorp.com)